

:

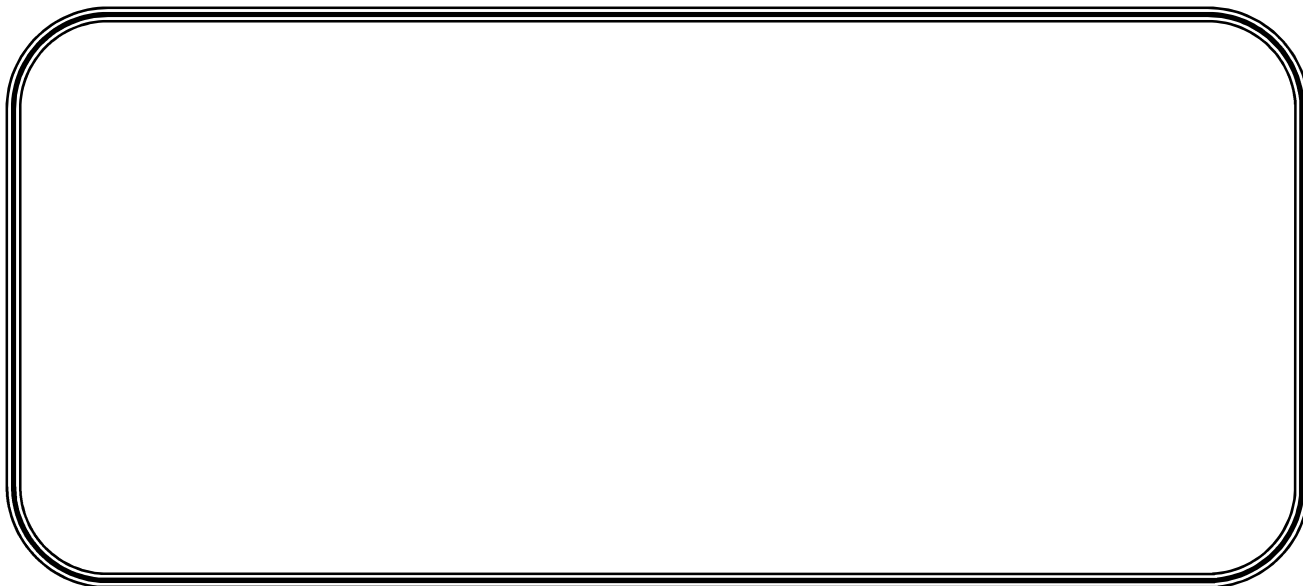

:

:

:

-

-

2014/2013 :

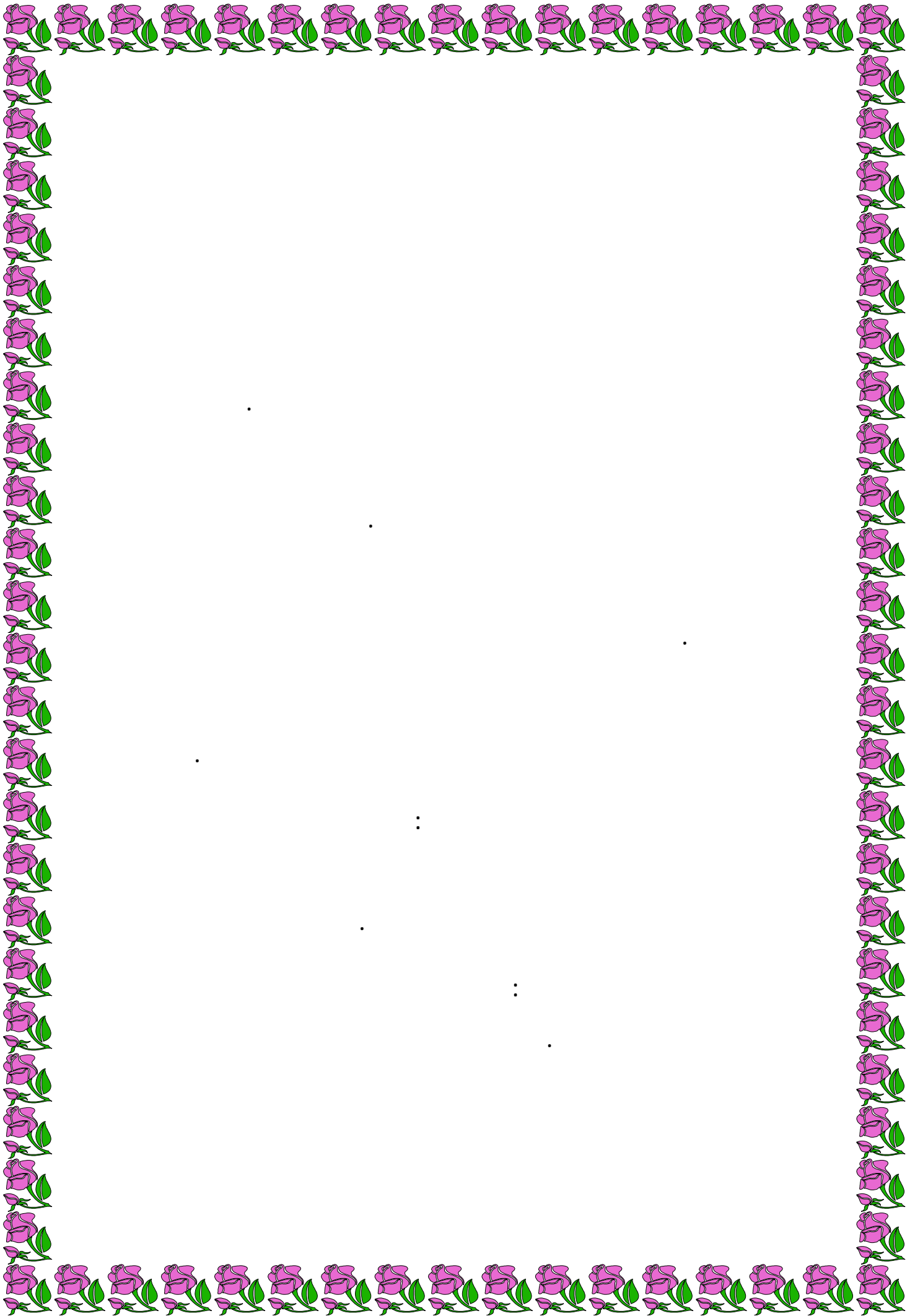

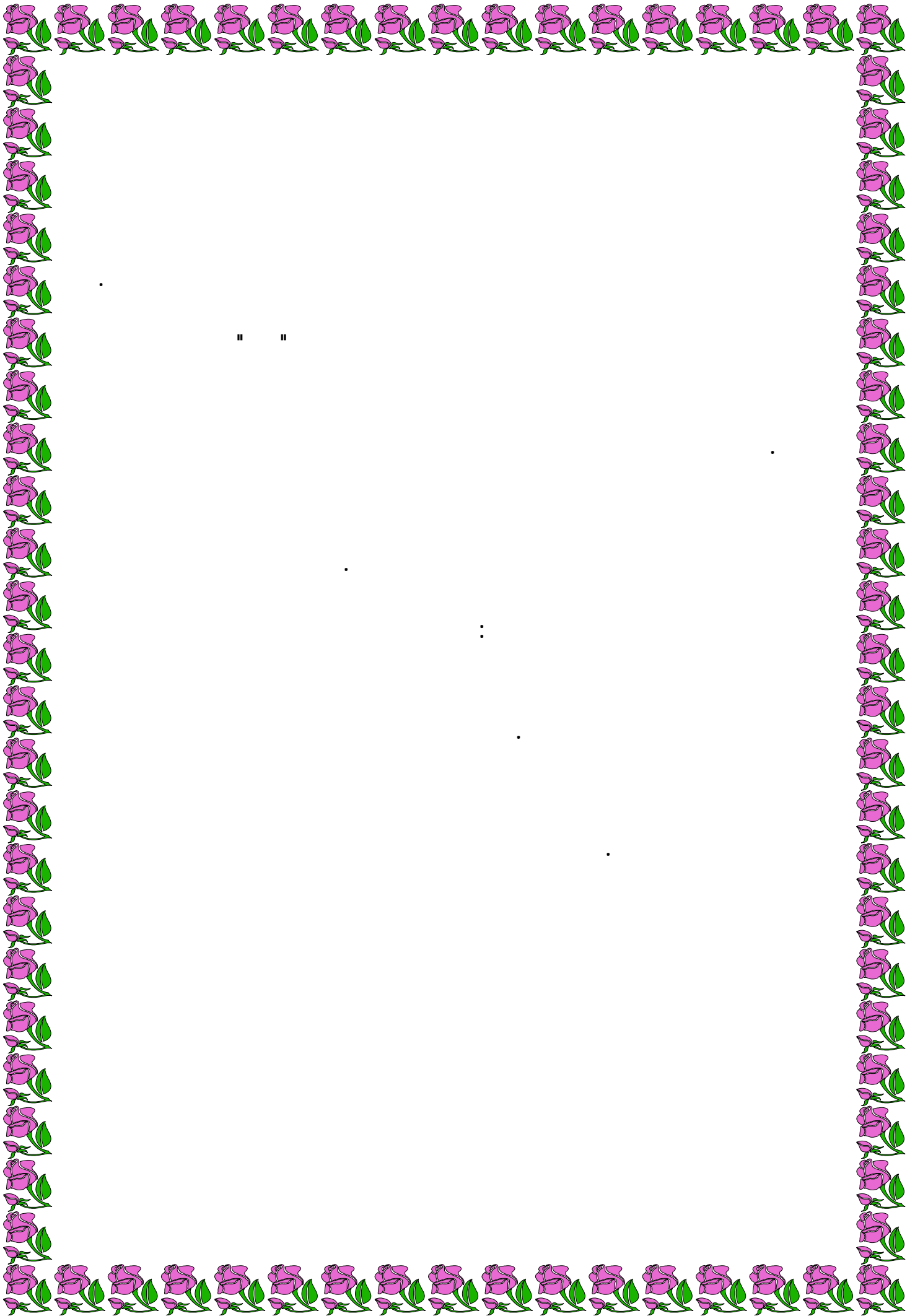



||

||

.







.

.

:



-

-

-

.

-

:

.

. ( ) :

:

:

.

"

" :

.

" " :

.

:

.





"

"

:

:

.

"

.

:

"

.

.

.

:

:

.

:

-

.

-

.

:

-

-

.

:

:

-

:

.



( )

.

.

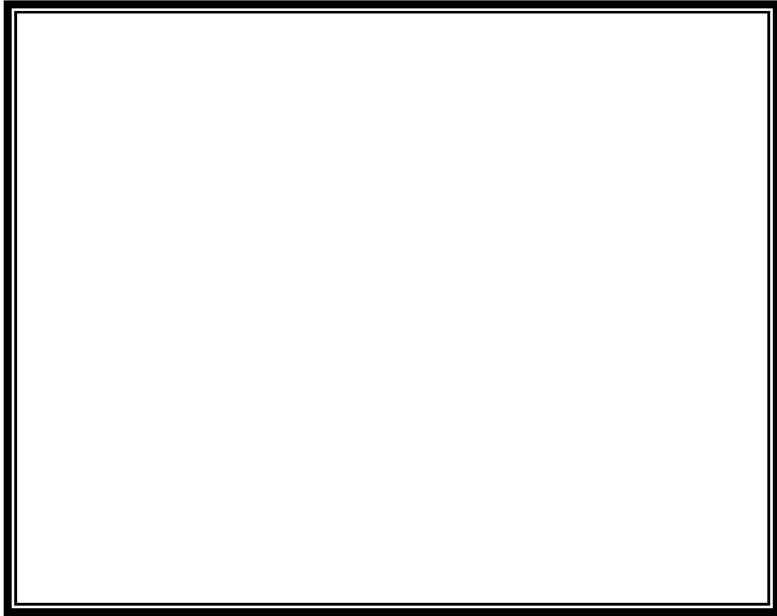

) ( )

(

.

.

:

- -

" :

"(1)"

: :

" :

2

\_\_\_\_\_  
\_(1)

.870

(1)»

» » »

(2)»

:

» :

(3)»

)

» :( CooleyC.

i1 ( ) \_ (1)  
.673 2003 :  
.21 2007 : - 1 \_ (2)  
\_ (3)  
.43 2009-2008 :

(1)»

.

»

(2)»

.

:

•

»

»

:

»

.

»

»

:

( )

.

.23

\_\_\_\_\_  
\_(1)

.20

\_\_\_\_\_  
\_(2)

/ ( )

/

/

.

:

•

( )

.

"

( )

(1)"

.

)

( )

(

.

:

\_\_\_\_\_  
\_(1)

:

»

«(1)

»

«(2)

:

---

(1) شفيقة علوي، محاضرات في المدارس اللسانية المعاصرة، أبحاث للترجمة والنشر والتوزيع، ط1، بيروت، 2004، ص 12.

(2) جان بيرو، اللسانيات، ت ر: الحواس مسعود و مفتاح بن عروس، سلسلة العلم والمعرفة، دار الأفق، الجزائر، 2001، ص 4.



.

:

” ”

.

:

:

/ :

”

”(1)

.

---

(1)- الطاهر بن حسين بومزبر، التواصل اللساني والشعرية ( مقارنة تحليلية لنظرية رومان جاكبسن)، الدار العربية للعلوم – ناشرون - ، ط1، بيروت، 2007، ص 24.



«(2)»

»

«(1)»

:

**:Code**

icode

»

»

«(2)»

( )

»

codage

décodage

(2) - الطاهر بن حسين بومزير، التواصل اللساني والشعرية، ص 25.

(1) المرجع نفسه، ص، 31.

(2) عبد القادر الغزالي، اللسانيات ونظرية التواصل، ص 28.

:

"

(1)"

"

:

(2)."

)

(

(3).:

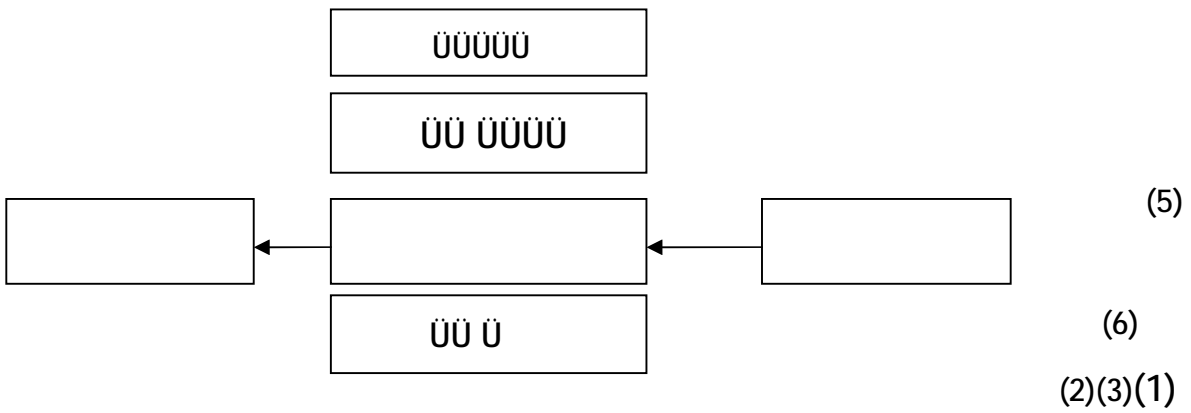

(1) رايبص نور الدين، نظرية التواصل واللسانيات الحديثة، ص 316.

(2) المرجع نفسه، ص 320.

(3) - الطاهر بن حسين بومزبر، التواصل اللساني والشعرية، ص 34.

(4)

:

" "

)

(

.

":

:

.(1)"

( )

.

:

"

(1) جمعان بن عبد الكريم، إشكالات النص، ( المداخلة أنموذجا)، ط1، المركز الثقافي العربي، الدار البيضاء: 2009، ص 33.

(2)»

(1)»( )

( )

( / )

( )

(2) نقلا عن رابح بوحوش، اللسانيات وتحليل النصوص، عالم الكتب الحديثة، ط1، أريد، ص 100.  
(1) فهيمة لحوحي، استراتيجية الخطاب في كتاب الإشارات الإلهية والأنفاس الروحانية لابي حيان التوحيدي، مذكرة الماجستير في اللغة العربية، باتنة 2003، ص 27.

(2)»

»

»

(1)»

.

»

(2)»  
i

/ ) :

:

.

---

(2) ماريو أوين، الإتصال والتفاعل. [www.pdfactory.com](http://www.pdfactory.com)  
(1) رايس نور الدين، نظرية التواصل واللسانيات الحديثة، ص 275.  
(2) نور الدين أفاية، الحداثة والتواصل في الفلسفة النقدية المعاصرة، حوق الطبع محفوظة للناسر، ط2، بيروت 1998، ص 185.

. :

. -1

. -2

. -3

. -4





: -1

: 1-1

(1) "

(2)

: /2-1

" " "

(3) "

" "

\_(1)

.133 " "

.399 2002 : 1 \_ (2)

.375 2001 1 : \_ (3)



" " ف

i<sup>(1)</sup>"( )

( ) ( ) "

:

" "

" "

( ) ( )

(2) i "

" "

.

" " ف " "

:

.

-

.

-

.

-

.375

1

:

\_(1)

1

:

\_(2)

.217 2001



(1)

(2)

"

.

.

( )

:

.

-

.

-

.

-

.

-

.

-

.

-

1

:

\_(1)

.87

1

.218 .i2001

\_(2)



:

(1)

.

.

:"

"

-2

"

"

(2)

(Garfinkel) "

"

.87 2008

1

:

\_(1)

\_(2)

.135 2005



“ ”

(1) “ (... )

: 1-2

(2)

“ ” “ ”

“

2 :



\_(1)

.147

\_(2)

.82

---

(3)

" "

" " (Schegloff) " " (Jefferson) " " (Sacks)

" " (Turner) " " (Schenken)  
(Garfinkel)

(1)

1976 (Schutje) " (Kallmeyr) " "

1980 " " 1982 (Rehboke) " " (Henne)

(Jefferson) " " (Schegloff) " (Sacks) " "

.132

---

\_(3)

.83

\_(1)



“ ”

(2)

.

:

-3

:

:

1-3

“ ”

(Léthnomethodologie)

”

“ ”

- ”

---

(1)»

» » »

(1) »

»

(2)»

:

.134

---

\_(1)

i2010

:

\_(1)

.23

.135

\_(2)





.

.

# Acte de Langage

"

(3)"

.

:

2-3

"

" (Hymes) "

"

(1)

.

.51

\_(3)

.136

\_(1)



“ ” “ ” “ ” “ ”

“ ”

“ ” “ ” “ ”

1970 “ ”

: “ ”

“ ” (2)“ ”

.

“ ” “ ” “ ”

“ ” (1)“ ”

“ ”

.203

\_(2)

.209

\_(1)



(2) : " "

:

) ( ) Cadre(Setting): -

.

(Participants) -

(1)

.

:(Ends) Finalités : -

." "

.212 2007 : 1

---

.211 \_ (2)

\_ (1)

---

( )

(Acts) Les Acts :

.  
:( )

):

.( ...

(Instrumentalités) Instruments:

.(...

)

( )

: (

)

.(

...

)

.(<sup>(1)</sup>

(Norms) Normes : -

)

---

(...

. ...

:Genre : -

( )

(

" ...

(2)"

" "

**Ethnomethodologie: 3-2**

( )

" " " "

" " " 1967

" " " " "

(1)"

---

.214 \_ (2)

1 : \_ (1)

.148 2005 :



— —  
" "

(2)"

: -4

:

"

(3)"

:

.149

\_(2)

\_(3)

.134



” ” ” ” ” ” ” ”

( ) ( )

(1)

”

(2)”

”

:

(3)”

.52

.52

.53

\_(1)

\_(2)

\_(3)



:

"

:

(1)"

.

"

(2)"

.

)

(3)

.(

|      |     |      |      |
|------|-----|------|------|
|      |     |      | _(1) |
|      | .52 |      | _(2) |
| .216 |     | .223 | _(3) |





:

"

(1)

.

.

"

"

(

)

"

(2)"

.

(3)"

"

.224

\_(1)

.401

\_(2)

.402

\_(3)



"

(1)"

.

:

(2) "

"

.

:

( )

( )

( )

:

"

(... ) :

(3) "

.

.382

\_(1)

.386

\_(2)

.225

\_(3)



: -1

)

(...

: <sup>(1)</sup>( )

: :

.

: :

. (. )

: -3

"

(2)"

.

"

(3)"

.405 \_\_\_\_\_ \_ (1)

.406 \_\_\_\_\_ \_ (2)

.225 \_\_\_\_\_ \_ (3)



.

: -3

( ) :

" :

(1) "

.



.

.

-1

(1-1

(2

(3

.

(4

.

(5

.



:(La Sociolinguistique)

-1

(1)»

»

»

(2)»

:

.20

\_(1)

.20

\_(2)



.

.

.

:

-1-1

( )

:

:(La Sociologie de linguistique)

(1)»

»

:La Sociolinguistique

.

---

(2)»

»

(Ethno linguistique) :

»

(1)»

Langue La Sociologie de

(La Sociologie de linguistique)

:

:( Microsociolinguistique)

»

(2)»

»

:(Macrosociolinguistique)

---

.32

\_(2)

.33

\_(1)

20

\_(2)





(3)''

''

(4) ''

.

.

.

:

:

-2

-

.

''

-

(1)''

-

.

(2)''

''

-

.

.28 1996 : - 1

:

\_(3)

i2010

:

\_(4)

.58

.22

\_(1)

---

(3)''

''

-

-

-

:

-3

''

1939

i<sup>(1)</sup>''

''

1965

1996

(2)''

(

)

---

\_(2)

.58

\_(3)

.58

\_(1)

.31 1996 1

:

\_(2)



.

:

-4

:

:(Hayems)

"

(1)"

"

(2)"

1

..

---

\_(1)

.146 2005

.146

\_(2)

45



.

:(Michelle)

"

:

(1)"

.

"

(2)"

:

.

:(Thompson)

.

.

.220

\_(1)

.148

\_(2)



·  
:  
-5

·  
:  
" ( ) : 1-5  
(1)"

·  
"  
(2)"

· 218 :  
1 :  
\_ (1)  
\_ (2)  
.146 2005



"

(3)"

( / ) i( / )

( / ) i( / )

:

:

"

(1)"

"

.220 :

.146

\_(3)

\_(1)



: (2)»

i" " " :

" "

" " i" " :

.

:

.

"

(1)»

"

i (2)»

.

.218

.35

.36

\_(2)

\_(1)

\_(2)



:

( ) " (3)"

:

.

.

:

" " " "

.

"Glossia" " " "di "

" " " Bi

bilingualism Bi

" "

(1)

" " lingualism

.132

\_(3)

\_(1)

.81 1996





" :

(2)"

.

"

(1)"

.

---

|     |        |  |       |
|-----|--------|--|-------|
|     |        |  | _ (2) |
| .76 | 2002 : |  |       |
| .76 |        |  | _ (1) |





.

)

(

.

:

-1

.

:

:

1-1



(1)

.

( )

(1):

.

-

.

-

.

-

.

-

:

:

:

-

.

:

-

.

:

-

.65 2005:

\_(1)

1

\_(1)

.101

---

(2)

(3)

: 2-1

”

(1) ”

” ” ”

---

.102 \_ (2)

.( ) 111-107 2008 : \_ (3)

.66 2005 : \_ (1)



- -

(2)»

.

: 3-1

" :

.164 2008 :

---

\_(2)

---

(1)〃

.

.

〃 ( )

(1)〃 ...

.

〃

(2) .

.

1 ( )

---

.212 2009 :

\_(1)

.80

\_(1)

.81

\_(2)



:

(3)

:

:

4-1

"

(1)"

.127

.82

\_(3)

\_(1)





(2)

"

.

.

:

:

1-4-1

:

.

(1)

.

"

:

2-4-1

(2)"

.214 (

)

\_\_\_\_\_  
\_ (2)

.84

\_ (1)

.84

\_ (2)



(3):

.

.

:

-2

.

(1):

:

1 ( )

.85

\_(3)

\_(1)

.141 2006



-1

-2

-3

-4

-5

-1-2

-1

-2

-3

-4

-5

(1)

-3



.

(2)

.

:

.

:

-

.

:

-

.

:

-

"



---

(1)<sup>n</sup>

.

:

.216 (

)

---

\_(1)



( )

:

.

( )

.

" "

"

"

"

"

.



.

.

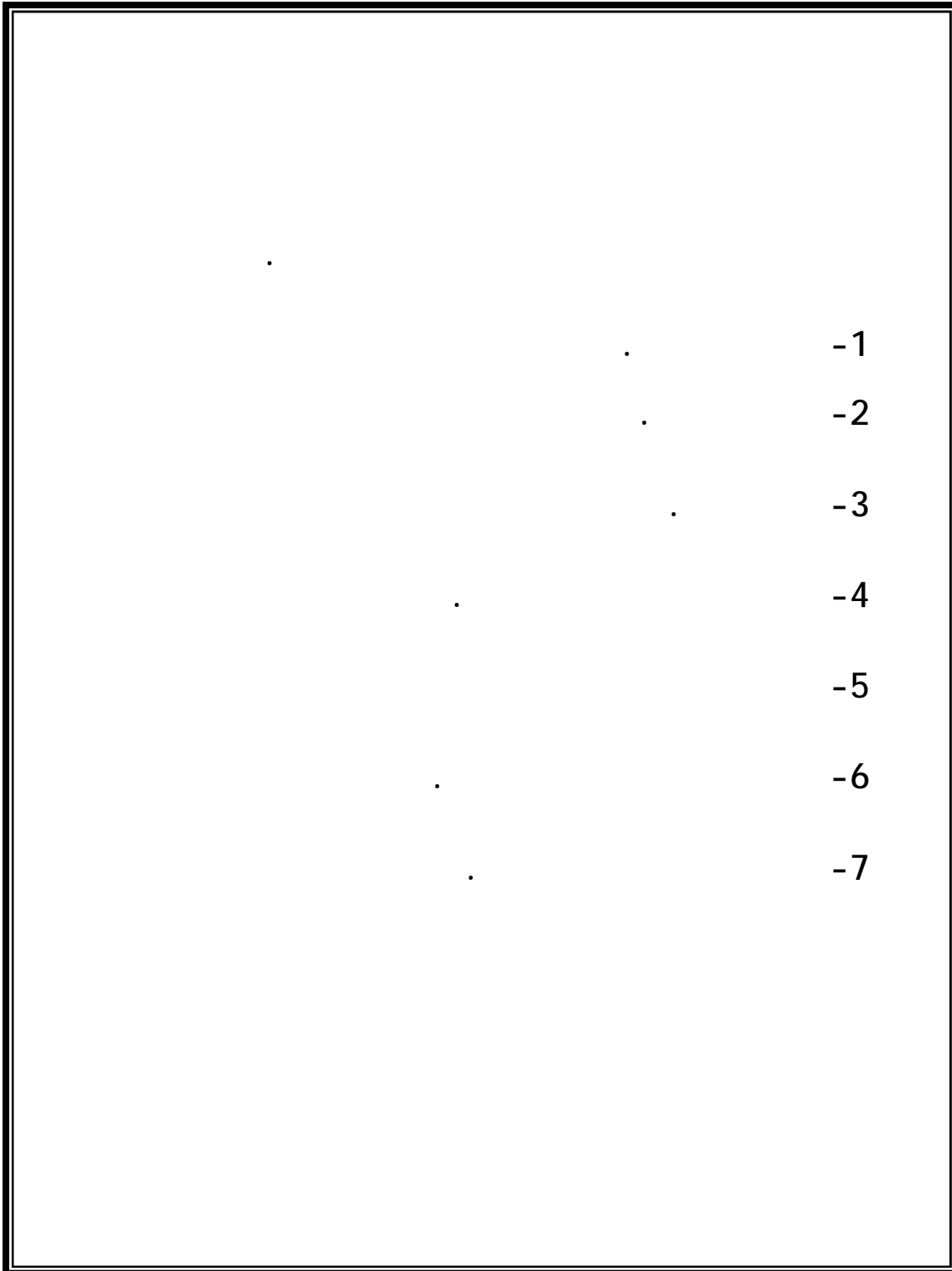



( )

( ) ( ) .

.

:

-1 :

.

:

": 09 2014 :

"

16 :2014 " :

27 :2014 " " :

07 : :2014 " " :

- 2013

:

-

2014

-

( )



:

-

.

-1

.

- 2

.

-3

.

-4

.

-5

.

:

)

(

.

:

-2

.

:

:

-

( )

:

( )

":

-

.

:

-

.

.( )

:

-

:

-

:1

-

:2

-

:3

-

:

-

:

-

.

:

-

- :1 .

- :2 .

- :3 .

:

- ":

- :

- :

- :

- :

- :

.

:  
:

( )

.

: -

:1 -

:2 -

:3 -

:4 -

: -

: -

: -

: -

:

: -

:1 -

.

:2 -

.

:

:

.

.

)

.(

:

"

":

"

":

"

"





.)

:

.

.

:

●

"

"

:

:

-

:

-

:

-

:

-

:

-

:

-

.

:

:

:

-

-

-

-

•

-

-

«

:

»:

«

.

-4

:

:

:

:

"

:

-

"

:

.

.

:

-

:

-

!

:

-

.

:

-

.

:

-

»:

. «

:

:

"

"

"

"

:

-

.

-

.

:

-

( )

.

-

-

.

-

.

-

.

.

-

:

\_5

:

"

"

.

:

-

.

:

-

"

"

:

-

:

":

-

.

:

-

.

:

-

."

:

-

.

" "

:

:

:

:

:

»":

«.

.

:

-

.

:

•

:

( ) :

" "

( ) :

» :

. «

( ) :

.....

" :

:

."

.....

:

●





.

- :

" "

)

.(

" "

" "

.

- :

"

"

( )

" ) :

/"

(

:

. :

. :

:

. :

:

. :

):

.(

.

:

:

:1

:

:2

:3

:4

( )

.

:

i( ) :

( )

.( )

( ) :

( )

.( )

: •

.

)

(

:

:

. :1

:2

:3

:4

.

:

-6

.( )

.

:

. : -

. : -

. : -

- :

:

:01

|   |   |
|---|---|
|   |   |
|   |   |
| . | - |
| . | - |

:02

|   |                  |
|---|------------------|
|   |                  |
|   |                  |
| . | - -Le téléphone. |
| . | - - Le Numéro.   |
| . | - - Les fraises. |

.

.

-7 :

( )

.

( )

( )

":

" /



" :

.( ) :

)

(

.



.

.

.

.

.

.

-1

-

:

-

-

:

-

-2

-3

.

.

:

-1

:

.

:

-

(1)

( )

(1):

. -

. -

. -

. -

: :

: -

. -

: -

.

:

-

(1)

(2)

:

"

(3) "

" " "

-

-

(1)"

.

:

-

.66 2005

.164 2008

---

\_(3)

\_(1)

" :  
(1)"

.

.

" ( )

(2)" ...

.

"

(3) .

.212 ( )

.80

.81

---

\_(1)  
\_(2)  
\_(3)



.

:

(1)

.

:

.

:

.

”

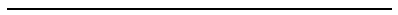

(2)

.

"

(1)

.

.

:

.

:

-

:

.

(2)

.

.

:

-

.127

1

.214 (

)

.84

\_(2)

\_(1)

\_(2)

"

(3)"

(1):

.

-

.

.

:

-2

(2):

-1

-2

-3

-4

-5

-1-2

-1

-2

-3

1 ( )

---

\_(2)

-4

.

-5

(1)

:

-3

.

(1)

.

:

.

:

-1

.

:

-2

---

\_(1)

.

.

\_(1)

·  
:

-3

”

(2)”

·

:

( )

:

·

( )

·

”

”

”

”

”

”

1 ( )

.216 2009

\_\_\_\_\_  
\_(2)







-

-

:

.

-

:

.

-

.

-

.

-

.

-

.

:

.

:

:

.

:

:

.

:

.

:

.

:

:

.

:





• :  
:

:

• :  
:

:

• :  
:

:

• :  
:

:

• :  
:

:

• :  
:

:

• :  
:

:

• :  
:

:

• :  
:

:

.

:

.

:

:

. 21 :

:

.

:

:

.

:

:

.

:

:

.

:

:

.( ) -:

.

-

.

-

:

⋮

•

•

⋮

⋮

•

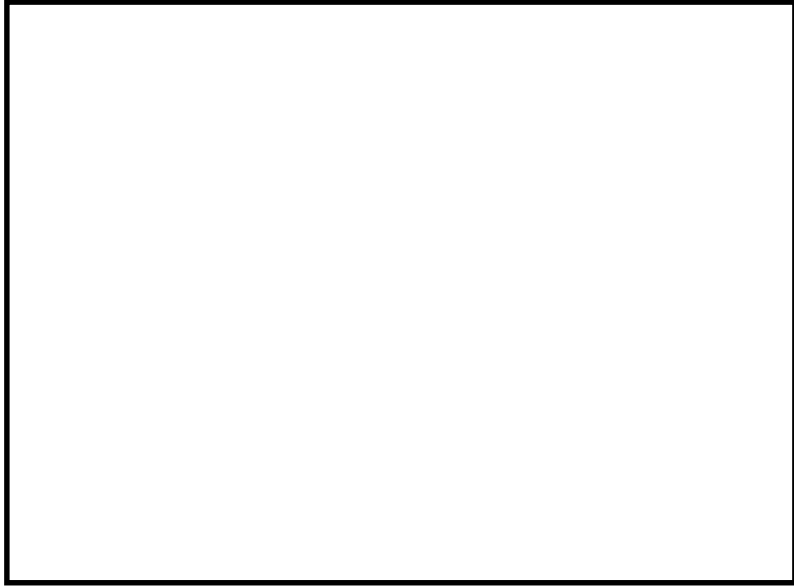



:

( )

:

.

( )

.

" "

" " " "

.





.

.

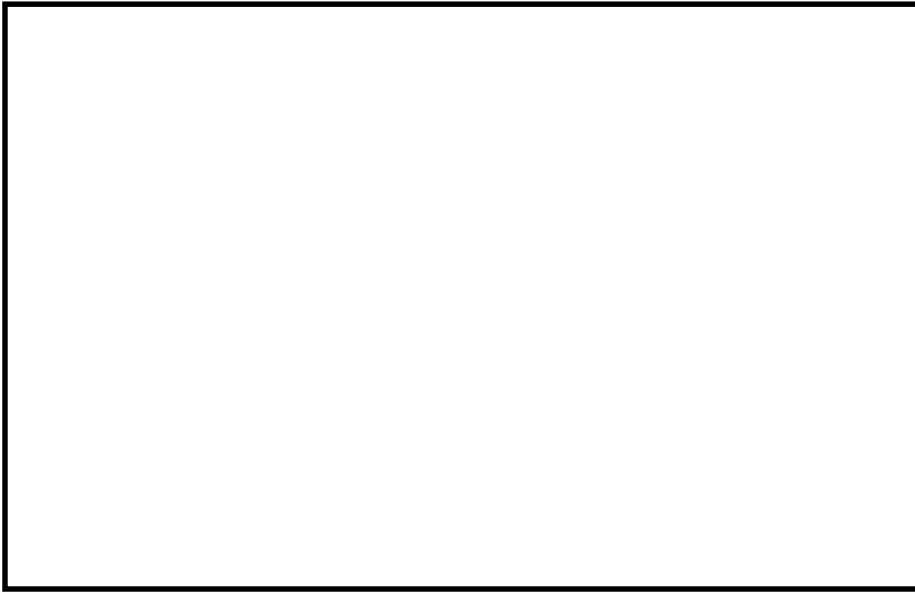

---

:

.2007

2

•

:

•

2005

3

•

.1996

•

.2004

:

•

.2010

1 :

:

•

.1996

i1

:

•

.2001

1

•

.

.2005

•

1

•

.2007

.2008

•

•

.1993

1



:  
 .2005 1  
 i1  
 .1990  
 1  
 .2010  
 i1  
 .1997 3  
 :  
 .2001 1  
 1 ( )  
 .2006  
 .2009 1 (



:

•

." "

. 1

•

( ) :

•

.2003 1

:

:

•

2009-2008

:

•

. 2003-2002

:

:

:

•

.2004

i1

•

.2007

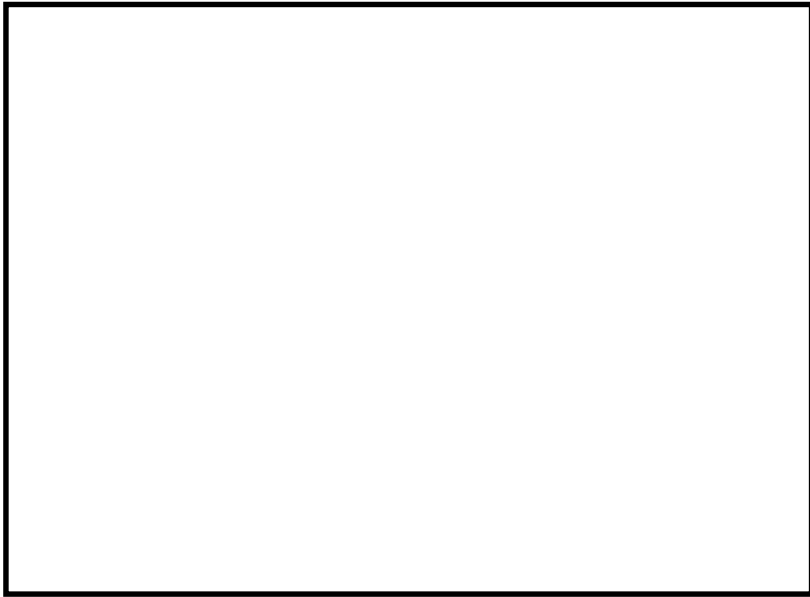



- - :

. - :

. -

. -

. -

. -

. :

. :

:

. :

:

. :

. :

. :

:

. :











.

:

.

:

:

. 21 :

:

.

:

:

.

:

:

.

:

:

.

:

:

.( ) -:

. -

. -

:



:

.

.

:

:

.

4-1.....

17-6.....

20..... -1

23..... -2

24..... 1-2

26..... -3

26..... 1-3

28 ..... 2-3

31..... 3-3

32..... -4

40..... -1

41..... 1-1

43..... -2

44..... -3

44..... -4

46..... -5

53..... -1

53..... 1-1

|         |     |
|---------|-----|
| 55..... | 2-1 |
|         | 3-1 |
| 56..... |     |
| 58..... | 4-1 |
|         | -2  |
| 59..... |     |
|         | -3  |
| 61..... |     |
| .       |     |
| 64..... | -1  |
| 67..... | -2  |
| 71..... | -3  |
| 74..... | -4  |
| 76..... | -5  |
| 84..... | -6  |
| 86..... | -7  |
| 89..... | -   |
| 95..... | -   |
|         | -   |
|         | -   |