

Investigations on the design, optimization and implementation of a rehabilitation system

Mohammed Sari, Manel Bouras, Soulef Boulkartous, Fadi Akram Boulebtina, Marouane Kohili

Department of Industrial Engineering, Faculty of Technology, University of Abou-BekrBelkaid ofTlemcen, Algeria
sarimohmoh@gmail.com

Abstract

This article explores the design, development, and implementation of an innovative device for hand rehabilitation, specifically targeting wrist injuries and post-surgical recovery. The device is developed using an Arduino platform and is designed to perform passive flexion-extension movements of the wrist, aiming to improve rehabilitation outcomes for patients with musculoskeletal disorders. The rehabilitation process is enhanced by integrating manual therapy, functional rehabilitation, and Proprioceptive Neuromuscular Facilitation (PNF) techniques, which have been shown to improve range of motion, strength, and pain management in hand and upper extremity injuries. Through 3D printing and the use of Arduino IDE, the device's components are precisely designed and tested to ensure compatibility and effectiveness. The device's design and functionality have led to the filing of a patent, underscoring its innovative approach to improving hand rehabilitation. This system offers a promising solution to enhance therapeutic results and reduce healthcare professionals' workload, contributing significantly to the field of medical rehabilitation.

Keywords

rehabilitation, motor, control, Bluetooth, degree, connection, mobile

1. Introduction

The rapid advancement of smart technologies has significantly transformed therapeutic practices in medical rehabilitation, particularly in the domain of hand rehabilitation. Patients recovering from injuries or medical conditions often face unique challenges that hinder their rehabilitation process. In this context, the integration of innovative technological solutions offers new, efficient, and optimized approaches to support and enhance recovery. This study focuses on the design and development of an intelligent hand rehabilitation system aimed at addressing these challenges. The Arduino platform, known for its flexibility and ease of programming, serves as the foundation for our device. Our primary objective is to explore how this open-source platform can be leveraged to create a personalized rehabilitation device that caters to the specific needs of individual patients.

In the first phase of this research, we conduct an in-depth analysis of the challenges encountered in hand rehabilitation. This includes understanding the medical conditions and types of trauma that affect the hand, as well as the specific needs of patients during their recovery process. The goal is to create a device that not only meets the clinical requirements but also provides a customized rehabilitation experience, contributing to more effective outcomes and a better quality of life for patients.

This article is structured as follows:

- Section 2: What is Rehabilitation - This section defines rehabilitation, highlighting its significance in the recovery process after injury or surgery. It will explain how rehabilitation techniques are used to improve functionality and quality of life for patients.

- Section 3: Literature Review on Rehabilitation Techniques - We will explore various rehabilitation techniques used in hand and upper extremity rehabilitation, such as kinesiotherapy, manual therapy, PNF, and tendon rehabilitation. The section will summarize existing studies and therapeutic methods that have proven effective in restoring function.
- Section 4: The Different Types of Rehabilitation - This section will discuss different types of rehabilitation, such as functional, neurological, respiratory, and orthopedic rehabilitation, and how these approaches are tailored to specific patient needs.
- Section 5: Anatomy of the Human Hand and Its Rehabilitation - Focusing on the anatomy of the hand, this section will provide insights into its structure and how understanding these functions aids in designing effective rehabilitation techniques and devices.
- Section 6: Device Design and Implementation - This section outlines the design and development process of the rehabilitation device, from conceptualization to implementation. We will also discuss the role of 3D printing, Arduino programming, and software simulation in creating a functional device.
- Section 7: Results and Discussion - This section presents the outcomes of the device testing and its functionality in a real-world rehabilitation setting, followed by a discussion of its effectiveness in improving patient recovery.
- Section 8: Conclusion - Finally, the conclusion will summarize the findings of the study and suggest future improvements, including further testing and potential applications in hand rehabilitation.

The goal of this article is to present the design of a cutting-edge hand rehabilitation system that combines innovative technology with personalized care, ultimately leading to improved therapeutic outcomes for patients. This device's development has led to the filing of a patent, highlighting its potential impact in the field of medical rehabilitation.

2. What is rehabilitation

Rehabilitation is a medical specialty which consists of caring for people affected by a handicap or physical incapacity, with the aim of minimizing the impact of this incapacity on all their activities. The objective is to improve their quality of life, as well as their autonomy.

Rehabilitation can also be indicated before and after a surgical operation: we then speak of pre-operative and post-operative rehabilitation. Indeed, no intervention is trivial; following surgery, you can sometimes expect symptoms such as pain or stiffness. The physiotherapist therefore intervenes after the operation, but also sometimes beforehand, so that you can regain your mobility and all your abilities. [1]

Definition. Rehabilitation consists, through body care and patiently repeated exercises, of regaining full use of what has been temporarily damaged by an injury. It also aims to learn how to best use the remaining functions following trauma, an accident or illnesses that reduce possibilities. Specifically, physical medicine and rehabilitation. Also called rehabilitation or physiatry, is a medical specialty which provides care for people with a disability or physical incapacity. [1]

3. Literature Review: Rehabilitation Techniques and Therapeutic Approaches in Hand and Upper Extremity Disorders

The field of hand rehabilitation and upper extremity musculoskeletal disorders has seen significant advancements in therapeutic techniques, ranging from manual therapy to kinesiotherapy and functional rehabilitation. This literature review explores the diverse approaches to rehabilitation, drawing on various studies and references related to the management and treatment of injuries in the upper limbs, particularly focusing on the wrist, hand, and tendons.

3.1 Functional Rehabilitation and Kinesiotherapy

Functional rehabilitation is a cornerstone of kinesiotherapy, especially in cases involving musculoskeletal impairments of the hand and upper extremities. According to the Institut Kiné Paris (2024) [1], functional rehabilitation focuses on restoring normal functional capacity by addressing joint stiffness, muscle weakness,

and pain, which are common issues following injuries. This approach includes joint mobility exercises and strengthening exercises, aiming to facilitate the recovery of functional independence in patients.

The *Passeport Santé* (2016) [2] highlights the importance of kinesiotherapy in the rehabilitation of upper limb injuries, especially after surgeries or trauma. Kinesiotherapy promotes tissue healing and enhances the body's capacity to perform everyday tasks by utilizing passive and active mobilization techniques.

3.2. The Role of Manual Therapy and PNF (Proprioceptive Neuromuscular Facilitation)

Manual therapy, including techniques like massage therapy and soft-tissue mobilization, plays a significant role in managing musculoskeletal disorders. Messina (2013) [6] discusses how manual therapy is used to treat conditions such as tendinopathies of the wrist, providing relief from pain and improving tissue mobility. This therapy aids in softening tissue adhesions, reducing stiffness, and improving blood circulation, which is crucial for rehabilitation.

In addition, Proprioceptive Neuromuscular Facilitation (PNF) is another key technique in hand rehabilitation. Adler et al. (2008) [9] describe PNF as a therapeutic method that enhances the range of motion (ROM) and muscular function. Hindle et al. (2012) [10] further confirm that PNF improves flexibility, reduces pain, and increases muscle strength, making it particularly effective for post-operative recovery or chronic musculoskeletal conditions.

3.3. Tendon Rehabilitation and Post-Surgical Recovery

Tendon rehabilitation, particularly after flexor tendon injuries, is a critical aspect of hand therapy. Groth (2004) [11] emphasizes the Pyramid of Progressive Force Exercises, which is used to facilitate healing after tendon injuries in the hand. The method involves progressively increasing the force and range of motion during rehabilitation, aiming to restore tendon function while minimizing the risk of re-injury.

The rehabilitation of tendon injuries often requires a balanced approach that combines immobilization during the initial healing phase and active rehabilitation exercises once the healing progresses. Fedorczyk (2011) [8] stresses the importance of manual therapy and strengthening exercises to promote proper tendon function and prevent complications such as tendon adhesion.

3.4. Evidence-Based Practices in Hand Rehabilitation

The growing focus on evidence-based practice in rehabilitation has improved the overall effectiveness of treatment. Skirven et al. (2011) [13] and Field (2016) [19] both highlight the significant improvements in treatment outcomes when scientific evidence guides the selection of therapeutic techniques, including manual therapy and PNF. Research consistently supports the effectiveness of these therapies for managing musculoskeletal disorders and improving the quality of life for patients recovering from hand injuries.

Moreover, Kelly et al. (2018) [15] reviewed the impact of randomized controlled trials in physiotherapy, concluding that therapies such as PNF and manual therapy have demonstrated substantial benefits in enhancing the functional capacity and range of motion in patients with hand and upper extremity injuries.

3.5. Advancements in Kinesiotherapy Techniques for Tendinopathies

Recent research, such as that by Messina (2013) [6] and Takata et al. (2018) [17], has focused on the effective treatment of tendinopathies in the wrist and hand. These studies underline the use of manual therapy alongside exercise therapy to address muscle imbalances, tendon injuries, and joint dysfunctions. The combination of soft-tissue therapy and active rehabilitation has been shown to significantly reduce pain and inflammation, thus facilitating a faster recovery.

The integration of functional exercises into rehabilitation plans helps patients regain motor skills, which is crucial for activities of daily living. Messina (2013) [6] further advocates for the implementation of scientific-based interventions to enhance rehabilitation efficacy, ensuring that patients recover to their optimal physical abilities.

3.6. Conclusion

The management and rehabilitation of hand and upper extremity musculoskeletal disorders require a multifaceted approach, combining manual therapy, functional rehabilitation, and evidence-based practices. Techniques such as Proprioceptive Neuromuscular Facilitation (PNF) and manual therapy have proven effective in improving range of motion, muscular strength, and pain management. The integration of these methods, particularly in post-surgical recovery and tendon rehabilitation, ensures that patients can regain functional independence and improve their overall quality of life. Building on these proven approaches, the following sections will focus on the design and implementation of a device specifically developed for hand rehabilitation. This device, which combines innovative technology and personalized rehabilitation, has led to the filing of a

patent, highlighting its potential to enhance therapeutic outcomes and contribute to advancements in hand rehabilitation.

4. The different types of rehabilitation

4.1. different types, adapted

Rehabilitation can be of different types, adapted to the specific needs of the patient. Here are some examples:

- *Functional rehabilitation*: Aimed at restoring motor or sensory functions after injury, illness or surgery.
- *Respiratory rehabilitation*: Focused on improving respiratory function, often used in the treatment of lung diseases or after thoracic surgery.
- *Neurological rehabilitation*: Designed to help people with neurological disorders regain motor, sensory or cognitive abilities.
- *Neurological rehabilitation*: Intended for people who have suffered heart problems, aiming to improve cardiovascular health and prevent future problems.
- *Orthopedic rehabilitation*: Focused on recovery after injury or orthopedic surgery, aiming to restore function and mobility to joints and muscles.
- *Vestibular rehabilitation*: Targeting balance disorders and dizziness by working on the vestibular system of the inner ear.
- *Urological rehabilitation*: Focused on improving pelvic floor function and bladder control in individuals with urological conditions through exercises, therapy, and education.
- *Voice rehabilitation*: Focused on restoring or improving voice quality in people suffering from voice disorders, such as dysphonia.
- *Cognitive rehabilitation*: Focusing on improving cognitive functions such as memory, attention and reasoning in people who have suffered traumatic brain injury, stroke or other neurological disorders.
- *Pediatric rehabilitation*: Adapted to the needs of children with developmental disorders, motor delays or complex medical conditions, aiming to promote their overall development.

4.2. How long does post-operative rehabilitation take

The total duration of rehabilitation after surgery varies greatly; this can range from a few weeks to 6 months in some cases. This depends on several parameters, such as your initial condition, the nature of the surgical operation, the other treatments you are following, and of course the pace of your evolution and progress. [2]

5. Anatomy of the human hand and its rehabilitation

Rehabilitation services are provided to patients who have lost the ability to perform normal daily tasks due to injury, stroke, infection, tumor, surgery or of a progressive disease such as arthritis. Rehabilitation needs concern all ages.

Many researchers combine various fields of engineering science with the medical field to study this topic. This helps meet the needs of people with disabilities and improve human capabilities. Today, only economic and moral questions can slow down its progress.

This is why our research and analyzes rely mainly on the physiology and anatomy of the human hand to better understand its functions.

5.1. Bones

The hand is made up of 27 bones: 8 carpal bones or carpals, arranged in two rows and forming, with the two bones of the forearm, the ulna and the radius, the wrist joint. The proximal row, the one closest to the ulna and radius, includes the navicular or scaphoid, the semilunate or lunate and the pyramidal or triquetrum. The distal row includes the trapezium, trapezoid, capitate or large bone, and hamate or hooked bone (so named because of the hooked projection it forms on the medial side of the hand).

5.2. Muscles

The 27 bones of the hand are connected by tendons to 36 muscles (including 8 for the thumb alone). Among these muscles, which move the wrist joint, the palm of the hand and the fingers, include flexors, extensors and muscles responsible for fine motor skills of the fingers, allowing both precision movements and gripping. The muscles responsible for finger and wrist movements are particularly numerous.

5.3. The different devices used in a rehabilitation center:

- Adult rehabilitation uses a variety of devices to assist patients in their rehabilitation process.
- Weight training equipment
- Electrical stimulation devices
- Joint mobilization and strengthening devices
- Devices for gait and balance rehabilitation

As well as pain treatment devices, these devices are used in a personalized manner according to the specific needs of each patient in order to promote their recovery and rehabilitation.

6. Device design

Hand and wrist rehabilitation is an essential procedure to restore the functions of these body parts after injuries or surgical procedures. To achieve this goal, several methodical steps must be followed, from design to implementation and operation. Our goal as university students is to create a device that helps injured people and reduces the work of doctors. To do this, we called on programmers, doctors and university professors.

6.1. Drawing of parts

To manufacture the device, it is necessary to draw each part individually using AutoCAD computer-aided design software. Once the designs are complete, these parts are then printed using a specialist 3D printing machine. These steps guarantee the precision and compatibility of the parts together, thus contributing to the manufacture of an effective and reliable device for hand and wrist rehabilitation. Figures 1-6 represent different part drawings of the device under consideration.

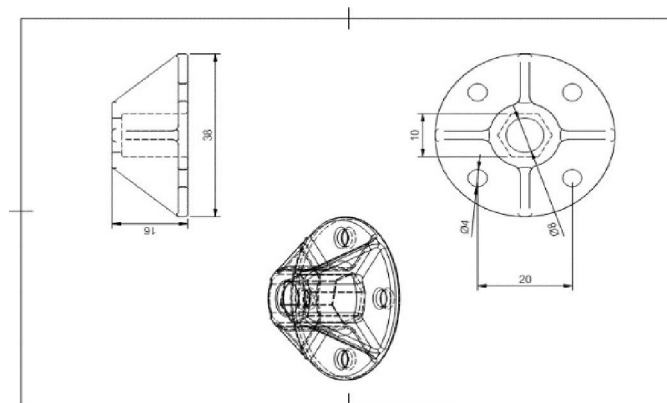

Fig. 1. Fixing flange

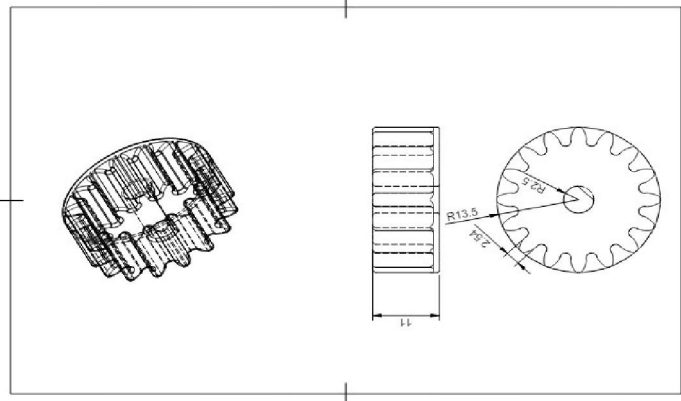

Fig. 2. Pinion gear

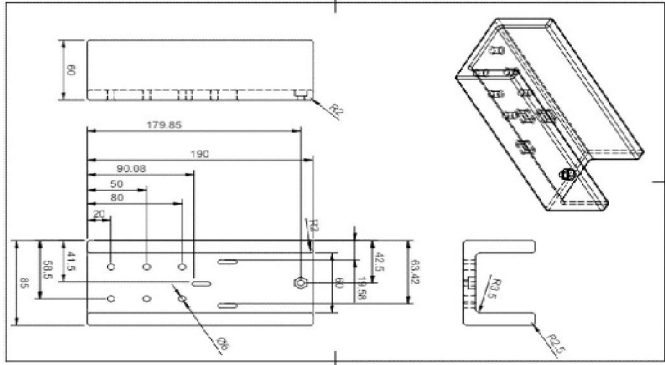

Fig. 3. Wrist positioning

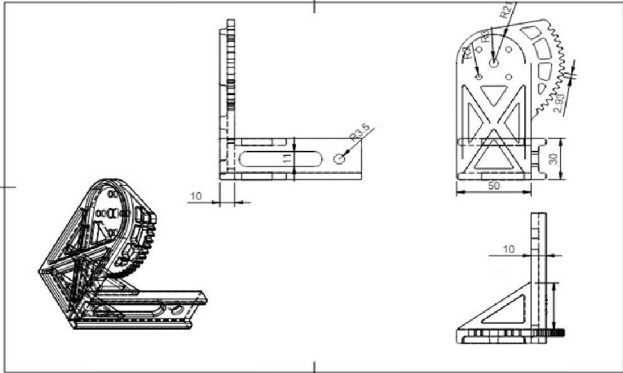

Fig. 4. Rotating pinion 1

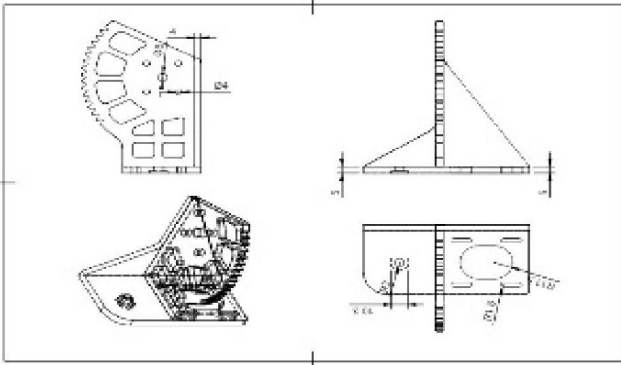

Fig. 5. Rotating pinion 2

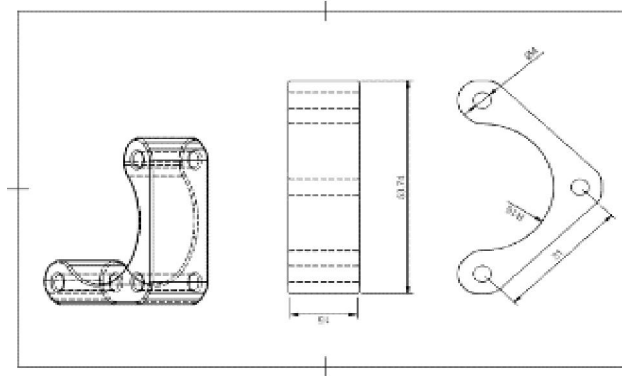

Fig. 6. Fixing bloc

6.2. Electrical implemetation

Arduino software is an integrated development environment (IDE) used to program Arduino microcontrollers. This IDE, often called Arduino IDE, allows you to write, compile and upload programs (called “sketches”) to Arduino boards.

Arduino is open-source, meaning its source code is freely accessible and editable by the community. It is available for different operating systems, including Windows, macOS and Linux. The software is a key tool for developing interactive and embedded electronics projects, allowing users of all skills to create and control electronic devices easily. [3]

6.3. Software simulation

Isis-Proteus is a very useful electronic simulation software for electronics students and professionals in the field. Here is some information about it:

6.3.1. Features of Isis-Proteus:

It allows you to simulate the operation of your electronic diagrams directly from your computer.

It offers a large number of options, making it a complete tool for simulation. You can also create documentation from your schematics.

Isis-Proteus is particularly suitable for the simulation of electronic circuits and microcontrollers1.

6.3.2. Use of Isis-Proteus:

You can use it to check how your designs work before implementing them in reality.

It is often used to simulate integrated circuits, microcontrollers (such as PICs), analog circuits, etc.

For students, this is a great way to learn and understand the principles of electronics without the need for physical hardware.

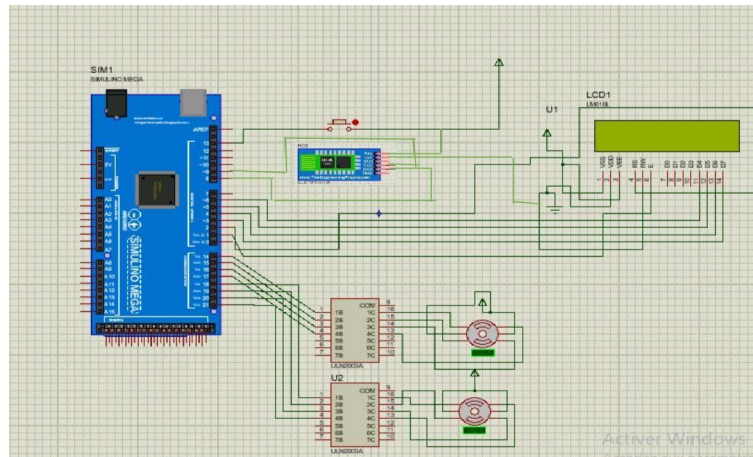

Fig. 7. Electrical circuit simulation

7. Results and Discussion

The developed device serves as an advanced physiotherapy tool, designed to facilitate passive flexion-extension movements of the wrist in a controlled and repetitive manner. Figures 8 and 9 illustrate the specific wrist movements—flexion, extension, and lateral inclination—that the device is programmed to perform, ensuring precise and continuous motion to aid in hand rehabilitation. These movements are essential for improving the range of motion and strengthening the wrist joint, which are critical factors in the recovery process, especially after injury or surgery.

The device consists of a fixed main arm, which supports the movement mechanism, and an adjustable mobile arm to accommodate the patient's forearm. The mobile arm is connected to a palmar support, which adjusts in depth to ensure the patient's palm is comfortably supported without causing pressure or tissue compression. Velcro straps securely hold the forearm in place, preventing unwanted movement during the therapy session.



Fig. 8. Flexion extension

Once the patient's upper limb is properly positioned, the device is activated. It initiates an alternating and continuous flexion-extension movement of the wrist, driven by the rotation and translation of the mobile arm. The movement stroke is pre-programmed, with a typical range between 80° - 90° for maximum palmar flexion and maximum dorsal extension, and 70° - 80° for radial and ulnar lateral inclination. Simultaneously, the metacarpophalangeal joints are passively flexed through the wrist's movements, further aiding the rehabilitation process.

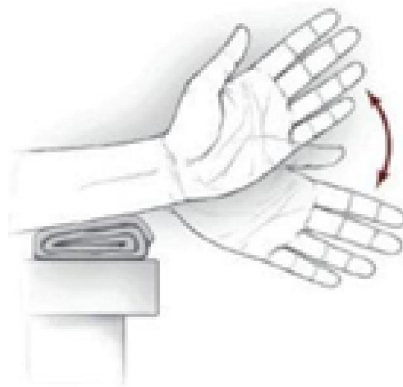

Fig. 9. Flexion extension

The speed, amplitude, and duration of the exercises can be finely tuned via a control box, allowing precise adjustments to match the patient's specific rehabilitation needs. The patient does not need to exert any active effort; instead, they undergo the prescribed movements passively, in a manner that mimics functional activities essential for regaining mobility and strength in the wrist.

Figures 8 and 9 show the flexion-extension movement facilitated by the device. This progressive, functional, and personalized approach to rehabilitation allows for gradual improvement while minimizing the risk of pain or joint damage, which is particularly important for patients recovering from trauma or surgery.

This device presents a promising solution to the significant medical challenge of hand and wrist rehabilitation. By integrating collaboration between programmers, healthcare professionals, and university professors, we aim not only to improve the quality of life for patients but also to reduce the workload of healthcare professionals. This innovative project, blending technical expertise with medical rehabilitation knowledge, underscores our commitment to contributing positively to functional rehabilitation and advancing medical innovation in the field of hand therapy.

8. Conclusion

This study presents the design and development of an innovative hand rehabilitation device utilizing the Arduino platform, combining advanced manual therapy, functional rehabilitation, and personalized treatment. By integrating modern technologies into rehabilitation practices, this device aims to address the specific challenges faced by individuals recovering from hand injuries and post-surgical conditions.

The literature review emphasized the importance of multifaceted rehabilitation approaches, including kinesiotherapy, PNF, and manual therapy, all of which have proven to enhance range of motion, muscle strength, and pain management in patients with hand and upper extremity disorders. Drawing on these proven methods, the rehabilitation device integrates passive movement to promote wrist flexion, extension, and lateral inclination, offering a controlled and progressive recovery process.

The design process, involving 3D printing, Arduino programming, and simulation software, has led to the creation of a device that not only addresses the clinical needs of patients but also provides a customized, functional rehabilitation experience. The successful development of this device has resulted in the filing of a patent, showcasing its innovative potential to enhance rehabilitation outcomes.

While this article outlines the initial design and testing phases, further research and development will be necessary to refine the device and expand its applications in hand rehabilitation. Future work will focus on optimizing the device's features, exploring its scalability, and conducting additional clinical trials to validate its effectiveness in diverse rehabilitation contexts. Ultimately, the goal is to create a practical tool that can assist healthcare professionals, reduce patient recovery times, and improve the overall quality of life for individuals undergoing hand rehabilitation.

Appendix

This work, the result of extensive research and technical innovations, has led to the filing of a patent (N# 2517), thus highlighting its groundbreaking nature and its significant contribution to the field.

References

- [1] Institut Kiné Paris, «institut kinesitherapie paris,» 04 janvier 2024. [En ligne]. Available:<https://www.institut-kinesitherapie.paris/actualites/types-reeducation-kinesitherapie/#:~:text=La%20r%C3%A9%20%C3%A9ducation%20fonctionnelle&text=Ce%20type%20de%20r%C3%A9%20%C3%A9ducation%2C%20qui,articulaire%2C%20difficult%C3%A9s%20fonctionnelles>. [Accès le 17 mars 2024].
- [2] M. Spée, «Passeport Santé Spécialités médicales Rééducation,» 07 2016. [En ligne]. Available: <https://www.passeportsante.net/fr/specialites-medicales/Fiche.aspx?doc=reeducation#quel-est-l-objectif-de-la-reeducation->.
- [3] «Isis-Proteus,» [En ligne]. Available: <https://www.toucharger.com/fiches/windows/isis-proteus/93955.htm>
- [4] Mesplé, G. (2012). Rééducation de la main Tome 1: bilan diagnostique, techniques de rééducation et poignet traumatique. Sauramps médical
- [5] Dufour, M. (2009). Masso-kinésithérapie et Thérapie manuelle pratiques - Volume 1. Elsevier Masson.
- [6] Messina, M. Traitement kinésithérapique des tendinopathies du poignet. In : SFRMGEMMSOR, Boutan M. Thomas D. Célérier S. Casoli V. Moutet F. (2013). Rééducation de la main et du poignet. Elsevier Masson. p.365-73
- [7] Kapandji, A. (2018). Anatomie fonctionnelle, Tome 1: Membre Supérieur. (7eme édition). Maloine
- [8] Fedorczyk, F. Manual Therapy in the Management of Upper Extremity Musculoskeletal Disorders. In : Skirven, T. Osterman, A. Fedorczyk, J. Amadio, P. (2011). Rehabilitation of the Hand and Upper Extremity (6eme édition). Elsevier Masson. p.1539-47
- [9] Adler, D. Beckers, S. Buck, M. (2008). PNF in practice: an illustrated guide. (3 eme edition). Springer.
- [10] Hindle, K. Whitcomb, T. Briggs, W. Hong, J. (2012). Proprioceptive Neuromuscular Facilitation (PNF): Its Mechanisms and Effects on Range of Motion and Muscular Function. Journal of Human Kinetics, 31 (11), pp.105-13. 10.2478/v10078-012-0011-y
- [11] Groth, N. (2004). Pyramid of Progressive Force Exercises to the Injured Flexor Tendon. Journal of Hand Therapy, 17(1), pp. 31-42. 10.1197/j.jht.2003.10.005.
- [12] Fabre, B. [2020, 24 avril] But du GEMMSOR. sfrm-gemmsor.fr. <http://www.sfrmgemmsor.fr/le-gemmsor--5-18.html>.
- [13] , J. Evidence, Based Practice in Hand Rehabilitation. In : Skirven, T. Osterman, A. Fedorczyk, J. Amadio, P. (2011). Rehabilitation of the Hand and Upper Extremity (6eme édition). Elsevier Masson. p.1881-89
- [14] HAS. [2020, 24 avril] Etat des lieux: Niveaux de preuve et gradation des recommandations de bonne pratique. [has-santé.fr. https://www.hassante.fr/upload/docs/application/pdf/2013-06/etat_des_lieux_niveau_preuve_gradation.pdf](https://www.hassante.fr/upload/docs/application/pdf/2013-06/etat_des_lieux_niveau_preuve_gradation.pdf)
- [15] Kelly, J. Reilly, G. Moloney, A. Moran, H. Cunningham, J. Broderick, C. (2018). 50 years of randomised controlled trials published in the journal of Physiotherapy: a review 1967-2017. Physiotherapy, 104(4), pp. 359-366. 10.1016/j.physio.2018.08.005
- [16] Pinsault, N. Monvoisin, R. (2014). Tout ce que vous n'avez jamais voulu savoir sur les thérapies manuelles. PUG

- [17] Takata, SC. Wade, ET. Roll, SC. (2018). Hand therapy interventions, outcomes, and diagnoses evaluated over the last ten years: A mapping review linking research to practice. *Journal of Hand Therapy*, 32(1), pp.1-9. 10.1016/j.jht.2017.05.018
- [18] HAS. [2021, 07 mars]. Syndrome du canal carpien: Optimiser la pertinence du parcours patient. has-santé.fr. https://www.has-sante.fr/upload/docs/application/pdf/2013-03/syndrome_du_canal_carpien_optimiser_la_pertinence_du_parcours_patient.pdf.
- [19] Field, T. (2016). Massage therapy research review. *Complementary Therapies in Clinical Practice*, 24, pp. 19-31. 10.1016/j.ctcp.2016.04.005
- [20] Piper, S. Shearer, HM. Côté, P. Wong, JJ. Yu, H. Varatharajan, S. et col. (2016). The effectiveness of soft-tissue therapy for the management of musculoskeletal disorders and injuries of the upper and lower extremities. A systematic review by the Ontario Protocol for Traffic Injury Management (OPTIMa) Collaboration. *Manual Therapy*, 21, pp. 18-34. 10.1016/j.math.2015.08.011
- [22] Field, T. Diego, M. Delgado, J. Garcia, D. Funk, CG. (2011). Hand pain is reduced by massage therapy. *Complementary Therapies in Clinical Practice*, 17(14), pp. 226-29. 10.1016/j.ctcp.2011.02.006