

**République Algérienne Démocratique et Populaire**

**Ministère de l'Enseignement Supérieure et de la Recherche Scientifique**

**Université Abderrahmane Mira**

**Faculté de la Technologie**



**Département d'Automatique, Télécommunication et d'Electronique**

## **Projet de Fin d'Etudes**

Pour l'obtention du diplôme de Master

Filière : Electronique

Spécialité : Instrumentation

### **Thème**

**Modélisation de l'irradiation solaire en fonction de paramètres météorologiques**

**Préparé par :**

Mr. HARCHECHE SAMIR

**Dirigé par :**

Mme K.OUALI

**Examiné par :**

Mr. L.TIGHZERT

Mme S.IDJDARENE

**Année universitaire : 2020/2021**

## **THANKS**

I WANT TO THANK THE GOD WHO PROTECTED AND GUIDED ME UNTIL THE END  
OF THIS WORK.

I AM VERY GRATEFUL TO MY TEACHER: MME K.OUALI WHO HELPED ME BY  
DIRECTING AND ENCOURAGING ME IN THE REALIZATION OF THIS WORK.

I EXPRESS MY SINCERE GRATITUDE TO HER FOR THE GREAT KINDNESS SHE ALWAYS  
SHOWED TOWARDS ME.

PLEASE FIND IN THIS WORK AN EXPRESSION OF MY GRATITUDE AND DEEP RESPECT.

## DEDICATIONS

NOT ALL LETTERS CAN FIND THE RIGHT WORDS ...

NOT ALL WORDS CAN EXPRESS GRATITUDE, LOVE, RESPECT, GRATITUDE.

ALSO, IT IS QUITE SIMPLY THAT:

I DEDICATE THIS THESIS

TO MY DEAR PARENTS

MOM, YOU BROUGHT ME INTO THE WORLD, AND SINCE THEN YOU HAVEN'T STOPPED LOVING ME, ENCOURAGING ME, TAKING CARE OF ME, BRINGING THE BEST WITHIN MY REACH; YOU SPARED NO EFFORT TO MAKE ME HAPPY.

DAD, YOU HAVE ALWAYS LOVED ME, SUPPORTED ME, ADVISED ME. YOU HAVE ALWAYS BEEN PRESENT IN MY LIFE AND ESPECIALLY IN THE MOST PAINFUL MOMENTS AS A STRONG AND COMFORTING PILLAR.

SO NO DEDICATION IS STRONG ENOUGH, NO WORD SPEAKS VOLUMES ENOUGH TO EXPRESS HOW I FEEL.

BUT THROUGH THIS WORK, THE CROWNING OF YOUR COMBINED EFFORTS, I WOULD LIKE TO EXPRESS TO YOU MY UNPARALLELED ESTEEM AND RESPECT, MY INFINITE GRATITUDE AND ABOVE ALL MY IMMENSE FILIAL LOVE.

MAY GOD GRANT YOU LONG LIFE, HEALTH AND HAPPINESS.

TO MY DEAREST SISTERS SARA AND SYLIA

AS A TESTIMONY OF MY BROTHERLY AFFECTION, OF MY DEEP TENDERNESS AND GRATITUDE, I WISH YOU BOTH A LIFE FULL OF HAPPINESS AND SUCCESS.

TO MY DEAR BROTHER SALEM

THROUGHOUT THE DEVELOPMENT OF THIS THESIS, YOU WERE PRESENT, YOU HELPED ME, ENCOURAGED ME THROUGH IT, I WOULD LIKE TO TELL YOU OF MY BROTHERLY LOVE AND MY UNWAVERING ATTACHMENT.

|                           |   |
|---------------------------|---|
| General introduction..... | 1 |
|---------------------------|---|

## **Chapter I : General notion on solar energy**

|   |    |
|---|----|
| I.1 Introduction.....   | 3  |
| I.2 Solar radiation.....  | 3  |
| I.2.1 Solar constant.....   | 3  |
| I.2.2 Extraterrestrial radiation (out of earth atmosphere).....       | 3  |
| I.2.3 Terrestrial radiation.....                                      | 4  |
| I.2.4 Solar spectrum.....   | 4  |
| I.3 Solar irradiance.....   | 5  |
| I.4 Solar insolation.....   | 5  |
| I.5 Clearness index.....  | 5  |
| I.6 The Earth's geographic Coordinate System.....                     | 6  |
| I.6.1 Latitude.....   | 6  |
| I.6.2 Longitude.....  | 7  |
| I.6.3 Altitude.....   | 7  |
| I.7 The Sun's Position.....   | 8  |
| I.7.1 Hourly coordinates.....   | 8  |
| I.7.1.1 Sun declination.....  | 8  |
| I.7.1.2 Hour angle ( $\omega$ ).....                                  | 8  |
| I.7.2 Horizontal coordinates.....                                     | 9  |
| I.7.2.1 Elevation angle.....  | 9  |
| I.7.2.2 Solar azimuth.....  | 9  |
| I.8 Solar photovoltaic energy.....                                    | 9  |
| I.8.1 Energy conversion.....  | 10 |
| I.8.2 Photovoltaic Cell.....  | 10 |
| 1.8.2.1 Description and principle working of a photovoltaic cell..... | 10 |
| 1.8.2.2 Characteristic of A Photovoltaic Cell.....                    | 11 |
| 1.8.2.3 Influence of Temperature And Illumination.....                | 12 |
| 1.8.2.4 Cell conversion efficiency.....                               | 13 |
| 1.8.2.5 Equivalent circuit.....                                       | 14 |
| I.9 Conclusion.....   | 16 |

## **Chapter II : Meteorological parameters**

|                                     |    |
|-------------------------------------|----|
| II.1 Introduction.....              | 17 |
| II.2 Meteorological parameters..... | 17 |

|  |    |
|--|----|
| II.2.1 Temperature .....   | 17 |
| II.2.1.1 Thermocouple.....   | 17 |
| II.2.1.2 Thermistance .....  | 18 |
| II.2.1.3 Transistor and semiconductor thermal sensor .....                                     | 18 |
| II.2.1.4 Thermopile .....  | 18 |
| II.2.1.5 Quartz thermal sensors .....  | 18 |
| II.2.2 Pressure .....  | 19 |
| II.2.2.1 Piezoelectric pressure sensor.....  | 19 |
| II.2.2.2 Piezoresistive pressure sensor .....  | 19 |
| II.2.2.3 Capacitive pressure sensor .....  | 20 |
| II.2.3 Humidity sensors .....  | 20 |
| II.2.3.1 Capacitive humidity sensors.....  | 20 |
| II.2.3.2 Interdigital sensors .....  | 21 |
| II.2.3.3 Resistive humidity sensors .....  | 21 |
| II.2.3.4 Hair hygrometer .....   | 22 |
| II.2.3.5 Condensation hygrometer .....   | 22 |
| II.2.4 The wind .....  | 22 |
| II.2.4.1 Wind formation .....  | 23 |
| II.2.4.2 Wind speed.....   | 23 |
| II.2.5 Precipitation .....   | 23 |
| II.2.5.1 Definition of precipitations .....  | 23 |
| II.2.5.2 Precipitated water depth measurements .....   | 23 |
| II.2.6 Insulation measurement .....  | 24 |
| II.2.6.1 Campbell-stokes heliograph.....   | 24 |
| II.2.6.2 Fiber optic heliograph: .....   | 25 |
| II.3 Modeling of global solar radiation.....   | 26 |
| II.3.1 Sunshine-based models.....  | 26 |
| II.3.2 Cloud-based models.....   | 27 |
| II.3.3 Temperature-based models.....   | 28 |
| II.3.4 Other meteorological parameter-based models.....  | 28 |
| II.4 Conclusion.....   | 29 |
| <br><b>Chapter III : Solar radiation modeling in the function of meteorological parameters</b> |    |
| III.1 Introduction .....   | 29 |
| III.2 Changes in meteorological data .....   | 29 |

|  |    |
|--|----|
| III.3 Selection of data .....                | 29 |
| III.4 Evolution of meteorological data ..... | 30 |
| III.4.1 Global irradiation.....              | 30 |
| III.4.2 Insolation .....                     | 31 |
| III.4.3 Pressure.....                        | 31 |
| III.4.4 Temperature :.....                   | 32 |
| III.4.5 Relative humidity RH (%).....        | 32 |
| III.5 Global solar irradiation models .....  | 33 |
| III.6 Proposed empirical models .....        | 34 |
| III.6.1 Linear regression models.....        | 34 |
| III.6.2 Nonlinear regression models .....    | 35 |
| III.7 Results and discussion.....            | 36 |
| III.8 Conclusion.....                        | 39 |
| General conclusion.....                      | 40 |

**Chapter I**

Figure I.1: Spectral distribution of solar radiation. ....5  
Figure I.2: lines of latitude. ....6  
Figure I.3 : Lines of latitude and longitude. ....7  
Figure I.4: Photovoltaic effect in a solar cell. .... 11  
Figure I.5: Functional diagram of a photovoltaic cell. .... 11  
Figure I.6: Influence of light on current-voltage characteristics of a photovoltaic cell. .... 12  
Figure I.7: Influence of temperature on current-voltage characteristics of a photovoltaic cell..... 13  
Figure I.8: Influence of temperature on the power-voltage characteristic of a cell photovoltaic. .... 13  
Figure I.9 : Ideal PV-cell equivalent-circuit models: single-diode model. .... 14  
Figure I.10: PV-cell equivalent-circuit models: single-diode model. ....15

**Chapter II**

Figure II.6: Campbell-stokes heliograph. .... 24  
Figure II.7 : Fiber optic heliograph. ....25

**Chapter III**

Figure III.1: Global radiation (KWh /m<sup>2</sup>/d) during the year1999 in bejaia. .... 30  
Figure III.2: Daily evolution of global horizontal radiation for the period: 1999-2000 ..... 31  
Figure III.3: Pressure (hpa) during 1999 in bejaia. .... 31  
Figure III.4: Temperature (°C) during 1999 in bejaia. .... 32  
Figure III.5: The humidity relative during 1999 in bejaia. .... 33  
Figure III.6: Comparison between the measured and calculated daily global horizontal radiation by the model 12.....38  
Table III.1: New coefficient of the models ..... 36  
Table III.2: Statistical results for the validation (MBE and RMSE). .... 37

# *General Introduction*



### **General introduction**

The growing demand of energy in our modern industrial life requires the search for alternative energy sources outside the limited and polluted current sources, such as fossil fuels. In a difficult energy and economic context, expectations in terms of energy renewables, in its various forms, such as wind and solar energies are increasing in importance, as they are an interactive, available and environment friendly solution.

The installation of any solar energy system in a given site requires preliminary studies. Indeed, sizing and simulation are essential to ensure optimal operation. To carry out such tasks, reliable measurements over relatively long periods of certain meteorological variables, and especially those of solar radiation, are essential.

Unfortunately, measurements of solar radiation are generally inaccurate and rare worldwide; especially in Algeria, due to the high price of measuring devices. There are only a small number of solar radiation stations, which is why there is a lack of solar radiation measurements in large areas on the one hand. On the other hand, where these data exist, there are generally periods of failure due to failures or low monitoring.

However, other meteorological parameters such as temperature ambient, humidity, wind speed are relatively easily measured in a larger number of weather stations with a relatively low cost compared to that of radiation. On the other hand, the optimization of a solar system or the simulation of its performances require at least, daily data, even, schedule of solar irradiation. [1]

Therefore, our objectif is to develop relationships between available meteorological data and solar irradiation; and to develop models to predict solar irradiation.

The thesis is organized as follows:

In the first chapter, we will give reminders about solar energy, then we will study the different geographical and astronomical parameters that can influence the intensity of solar irradiation received at ground level and we will end with a modeling of a photovoltaic cell.

In the second chapter, we will give a general view of some meteorological sensors.

The use of data from some meteorological parameters to generate the different models, as well as the evaluation of the performance of the models obtained will be presented in the last chapter.

Finally, we will end our work with a general conclusion and perspective.

**CHAPTER I**  
**GENERAL NOTIONS ON SOLAR ENERGY**

## I.1 Introduction

Solar energy is the most dominant of all renewable energies; it is one of the most easily exploited. Like most soft energies, it gives the user the possibility of meeting their needs without an intermediary. Knowledge of the position of the sun in the sky at any time and in any place is necessary for the study of intercepted energy. The times of sunrise and sunset as well as the trajectory of the sun in the sky during a day make it possible to evaluate certain quantities such as the maximum duration of insolation, the global irradiation .

In this chapter, we will define certain solar quantities namely: astronomical quantities, geographic quantities, solar radiation outside the atmosphere, and solar radiation in the terrestrial atmosphere. Finally, we introduce the notion of the photovoltaic effect and the photovoltaic solar generator .

## I.2 Solar radiation

Solar radiation is the energy per unit vicinity in the shape of electromagnetic radiation emitted by the Sun in spectral regions ranging from X-rays to radio waves. Terrestrial applications of renewable energy utilizing solar radiation generally rely on radiation, or photons referred to as “optical radiation” . [2] [3]

### I.2.1 Solar constant

The mean solar flux on the plane perpendicular to the direction of the rays and their position outside the Earth's atmosphere is called the solar constant I. The average value is currently equivalent to 1373W/m<sup>2</sup> Earth-Sun distance change during the year affects the value of the solar constant . [4]

### I.2.2 Extraterrestrial radiation (out of earth atmosphere)

Extraterrestrial solar radiation covers an extensive range of wavelengths. It does not depend on any meteorological parameters. Still, it depends on some parameters astronomical and geographic such as the latitude of the place ( $\varphi$ ), the solar declination ( $\delta$ ), and the hour angle at sunset ( $\omega_s$ ). On a horizontal surface, and for day d, extraterrestrial radiation  $H_0$  (W/m<sup>2</sup>) is obtained from the following equation: [5]

$$H_0 = \frac{24 \cdot 3600}{\pi} I_{sc} \left( 1 + 0.033 \cos \left( \frac{360D}{365} \right) \right) \times \left( \cos \varphi \cdot \cos \delta \cdot \sin \omega_s + \frac{2\pi \cdot \omega_s}{360^\circ} \cdot \sin \varphi \cdot \sin \delta \right) \quad (I.1)$$

Where:

$I_{sc}$  Is the solar constant .

$D$  is the number of days of the year starting from the first of January.

### I.2.3 Terrestrial radiation

As it passes through the atmosphere, solar radiation is absorbed and scattered and it undergoes a number of alterations and random attenuation crossing the atmosphere. On the ground, there are several components: [6]

- ✓ **Direct solar radiation:** this is the radiation received directly from the sun, without scattering.
- ✓ **Diffuse radiation:** it is made up of light diffused by the atmosphere (air, cloudiness, and aerosols).
- ✓ **The albedo:** this is the part reflected by the ground. It is determined using an albedometer device and depends on the site environment.
- ✓ **Global solar radiation:** this is the sum of the different radiations.

### I.2.4 Solar spectrum

Electromagnetic radiation is made up of "grains" of light called photons. The energy of each photon is directly related to the wavelength  $\lambda$  .

Every hot body emits radiant energy which is characteristics of body temperature, size and nature of its surfaces .

The spectrum of solar radiation too is characteristic of sun's temperature. However, since sun's energy is generated at its centre, which has a temperature of millions of degree, the central hot core terminates in a relatively colder surface called photosphere. For the purpose of solar spectrum and the corresponding temperature of sun, we always consider the temperature of photosphere. As viewed outside the earth's atmosphere, the spectrum of solar radiation is characteristic of that emitted from a black surface at a temperature of 5762 K. This implies that the solar spectral irradiance ranges between the wavelength region of 0.2–2.0  $\mu\text{m}$  and has maximum invisible light region at 0.48  $\mu\text{m}$  . The brightness of solar disc also varies from its centre to edges. However, for engineering calculations, the disc is often assumed to be of uniform density . And the following figure I.1 shows the Spectral distribution of solar radiation .[7]

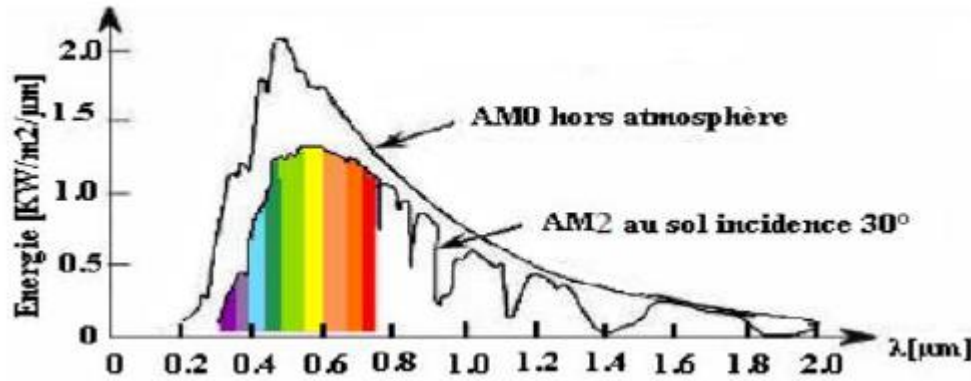


Figure I.1: Spectral distribution of solar radiation. [8]

### I.3 Solar irradiance

The solar irradiance is the output of light energy from the entire disk of the Sun, measured at the Earth.

We can also say it is the quantity of energy received at the ground level per unit area. Irradiance is an instantaneous measurement of solar power over some area. The units of irradiance are watts per square meter

### I.4 Solar insolation

Insolation is the incident solar radiation onto some object, the incoming solar radiation, or the amount of solar radiation received at the Earth's surface. Specifically, it is a measure of the solar energy that is incident on a specified area over a set period. Generally, insolation is expressed in two ways. One unit is kilowatt-hours per square meter ( $\text{kWh/m}^2$ ) per day which represents the average amount of energy hitting an area each day. Another form is watts per square meter ( $\text{W/m}^2$ ) which represents the average amount of power hitting an area over an entire year.

### I.5 Clearness index

The clearness index is a measure of the clearness of the atmosphere. It is the fraction of the solar radiation that is transmitted through the atmosphere to strike the surface of the Earth. The clearness index has a high value under clear, sunny conditions, and a low value under cloudy conditions.

The clearness index can be defined on an instantaneous, hourly, or monthly basis. The symbol for the monthly average clearness index is  $K_T$ .

A clearness index is a dimensionless number between zero and one, indicating the fraction of the solar radiation striking the top of the atmosphere that makes it through the atmosphere to

strike the Earth's surface. It is defined as the ratio between the overall horizontal irradiation  $H_G$ , and the extraterrestrial irradiation  $H_0$ : [9][10]

$$K_T = \frac{H_G}{H_0} \quad (I.2)$$

## I.6 The Earth's geographic Coordinate System

The first step in converting the information contained in the real-world onto a 'piece of paper' was to devise a system where everything could be uniquely located in the world.

Very early maps (which usually showed small local or regional areas) used a grid technique that relied on simply measuring the distance and direction between points of interest and then plotting these onto the 'piece of paper'. This method assumed that the Earth was flat.

With the general agreement that the Earth was, in fact, round, a different methodology needed to be developed. The system that has been developed over many centuries is called latitude and longitude.

The location and measurement of latitude and longitude essentially involve complex mathematics (especially geometry) and a series of international agreements/conventions for recording locations on the surface of the Earth.

### I.6.1 Latitude

It was agreed that a line around the center of the Earth would be called the Equator. This would be numbered as zero degrees ( $0^\circ$ ) of latitude. From the Equator, a series of parallel lines were recognized with the most northern and southern points being called the North Pole and the South Pole. These would be numbered as 90 degrees North and South respectively ( $90^\circ\text{N}$  and  $90^\circ\text{S}$ ).



**Figure I.2:** lines of latitude.

### I.6.2 Longitude

Defining longitude was difficult, as it could not be based on observations of the movement of the sun. It was, in part, influenced by the discovery of Magnetic North, but ultimately longitude is mostly based on abstract mathematical/geometric concepts.

It was agreed to have a series of radiating lines that run vertically around the Earth. They connected at both ends – i.e. at the North Pole and the South Pole. As a result of this, a series of ‘slices’ much like slices of orange are created. These are pointed at their ends and broadest in the middle.

It was also agreed that a primary line of longitude should be identified and that this should be zero degrees (0°) of longitude and Greenwich in the United Kingdom, was to be adopted as the standard primary line of longitude.

Radiating to the east and the west would be 180° of longitude. These would meet at the opposite side of the Earth and form a joint 180° line of longitude (with 180°E and 180°W being the same line). Lines of longitude are called meridians.

Combining the latitude and longitude gives us a system to record the location of any feature on the surface of the Earth uniquely.

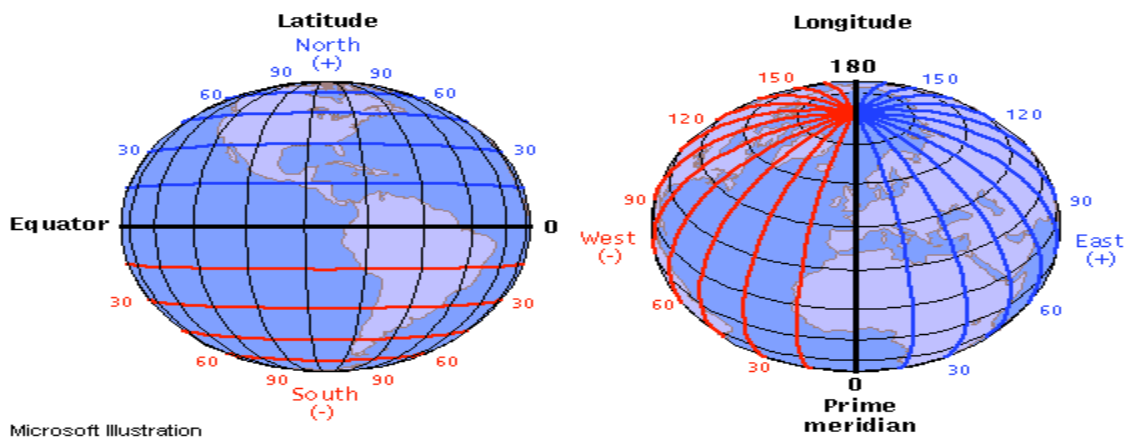


Figure I.3 : Lines of latitude and longitude.

### I.6.3 Altitude

Altitude or height is a distance measurement, usually in the vertical or up direction, between a reference datum and a point or object. Altitude is commonly used to mean the difference between a point and a mean level, usually the sea level (or level 0) of a location.[11][12]



## I.7 The Sun's Position

The earth moves in an elliptical orbit around the sun. The plane of rotation of the earth around the sun is called the ecliptic plane. Its rotation is carried out in one year, lasting 365 days and approximately 6 hours (hence the need for a leap year every 4 years).

The apparent position of the sun is identified at every moment of the day and of the year by two coordinate systems:

### I.7.1 Hourly coordinates

Hourly coordinates are used to position the sun. They are related to the time of observation, and have no relation to the position of the observer on earth. The hourly coordinates have as their reference plane the plane of the equator.

The hourly coordinates are two:

#### I.7.1.1 Sun declination

This is the angle formed by the Sun-Earth vector with the equatorial plane. It is due to the inclination of the Earth's pole axis relative to the elliptical plane, which is reflected by the different seasons. It varies during the year between  $-23.45^\circ$  and  $+23.45^\circ$ .

The daily variation in declination  $\delta$  is approximately  $0.5^\circ$ . It is calculated by an approximate simple equation:

$$\delta = 23.45 \left[ \sin\left(\frac{360(284+D)}{365}\right) \right] \quad (\text{I.3})$$

D: the number of days starting from the first of January.

#### I.7.1.2 Hour angle ( $\omega$ )

The Hour Angle converts the local solar time into the number of degrees at which the sun moves across the sky. By definition, the Hour Angle is  $0^\circ$  at solar noon. Since the Earth rotates  $15^\circ$  per hour, each hour away from solar noon corresponds to an angular motion of the sun in the sky of  $15^\circ$ . In the morning, the hour angle is negative, in the afternoon the hour angle is positive.

The sunrise hour angle  $\omega_s$  can be calculated if the latitude  $\varphi$  of the site and the solar declination  $\delta$  are known :

$$\omega_s = \cos^{-1}(-\tan \varphi \tan \delta) \quad (\text{I.4})$$

The solar angle at sunset is quite simply the opposite of the solar angle at sunrise.

### I.7.2 Horizontal coordinates

The horizontal coordinates are used to locate the sun, they depend on the place of observation. They have as a reference plane the horizontal plane, perpendicular to the vertical of the place. An object is located in this coordinate system by these components:

#### I.7.2.1 Elevation angle

The angular height of the sun, commonly called the height of the sun or the elevation of the sun, is the angle between the apparent direction of the sun and its projection on the horizontal plane of the place in question. Its value is zero at sunrise or sunset and maximum when the sun is at its zenith. It varies during the day depending on the declination  $\delta$  the hour angle  $\omega$ , and the latitude  $\varphi$ .

The elevation angle  $Y_s$  is given with the formula:

$$\sin Y_s = \sin \varphi \sin \delta + \cos \varphi \cos \delta \cos \omega \quad (\text{I.5})$$

Where:

$\varphi$  : the Latitude of the observation point ;

$\delta$  :the solar déclination angle;

$\omega$  : the solar hour angle.

#### I.7.2.2 Solar azimuth

The solar azimuth angle ( $a_s$ ) is the angle usually measured clockwise from true north around the observer's horizon. It is the angle between the local meridian and the vertical plane passing through the sun, zero azimuth, corresponds to the south direction in the northern hemisphere and the north direction in the southern hemisphere, The azimuth angle is positive in the east (+90), negative in the west (-90) .[14]

The azimuth angle is given with the formula:

$$\sin \alpha = \frac{\cos \delta \times \sin \omega}{\cos h} \quad (\text{I.6})$$

### I.8 Solar photovoltaic energy

Photovoltaic solar energy, which is characterized by an absence of pollution, by its availability, has been the subject of great interest in recent years. Indeed solar energy can provide real solutions to the various problems that are currently posed concerning climate change, and energy crises.

### 1.8.1 Energy conversion

The photovoltaic effect was discovered by the French physicist A. Becquerel in 1839. The word “photovoltaic” comes from the word “photo” (from the Greek “phos” which means “light”) and from the word “Volt” (patronymic of the physicist Alessandro Volta who made a very important contribution to electrical research) .

### 1.8.2 Photovoltaic Cell

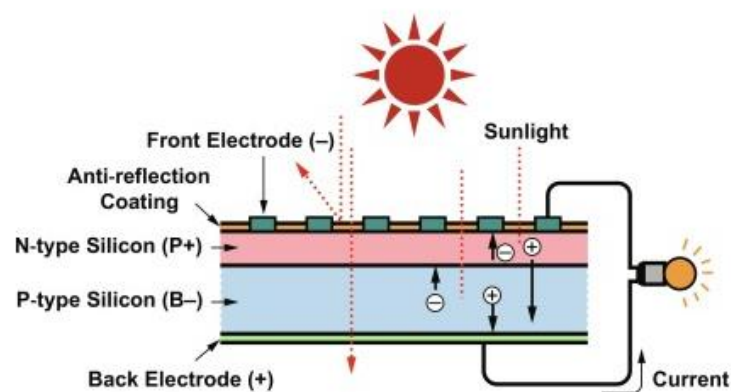
#### 1.8.2.1 Description and working principle of a photovoltaic cell

The simplest structure of a PV cell is composed of two thin semiconductor layers doped differently, one is of type n and the other is type p. It is at the junction of these two layers that the cell produces electricity. This junction is the p-n junction, which represents the heart of the cell photovoltaic.

When the photovoltaic cell is exposed to solar radiation, a photon incident in the p-n junction tears off an electron and thus creates a free electron-hole pair.

Under the effect of the electro-magnetic field, electrons accumulate in the n-doped layer, while the holes accumulate in the p-doped layer. This reaction then causes a difference of distribution of charges thus creating a difference in electrical potential between the two layers of the cell. This is the photovoltaic effect. Consequently, the electric current can circulate by connecting the junction terminals to an external circuit.

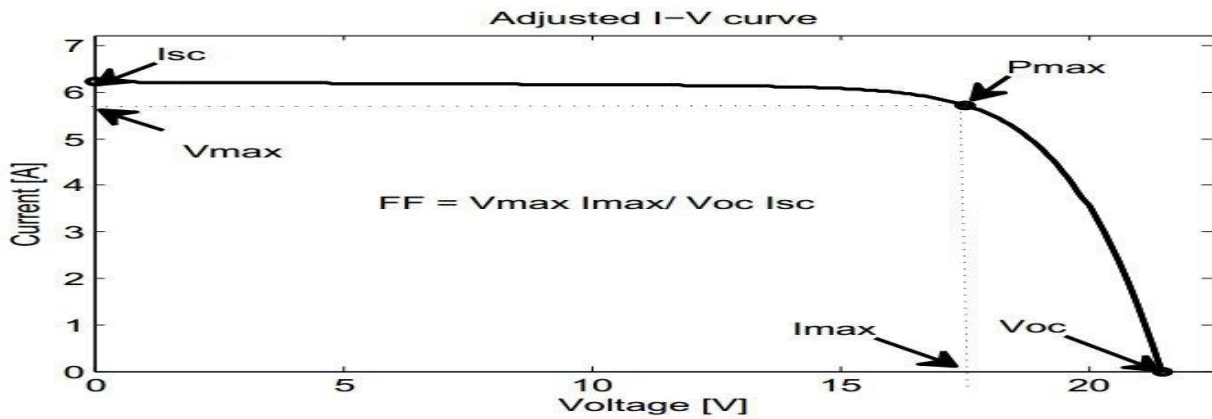
The operation of photovoltaic cells is illustrated in figure (I.4).



**Figure I.4:** Photovoltaic effect in a solar cell.

### 1.8.2.2 Characteristic of A Photovoltaic Cell

The operation of a cell can be represented by the curve  $I = f(V)$ , which indicates the evolution of the current generated by the photovoltaic cell as a function of the voltage at these terminals from the short-circuit, to the open circuit.



**Figure I.5:** Functional diagram of a photovoltaic cell. [8]

From the current-voltage characteristic, it is possible to deduce the electrical parameters of the pv cell:

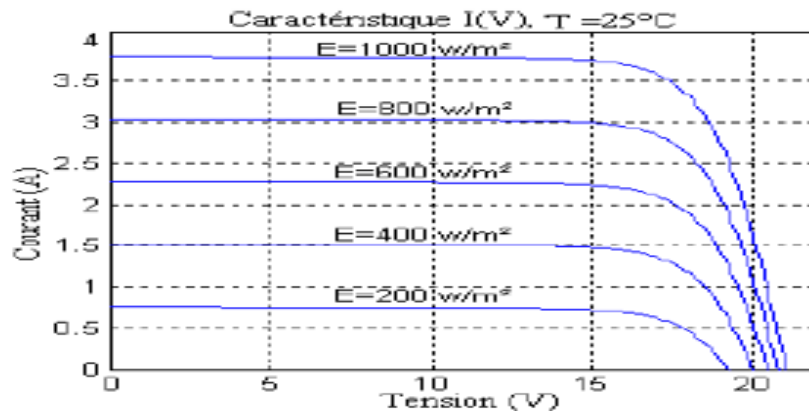
- **Open circuit voltage  $V_{co}$ :** If we place a solar cell under a constant light source, without any load at its terminal, it will produce a direct voltage of about 0.6 V, called open circuit voltage  $V_{co}$  (it varies slightly with temperature and lighting). This is the maximum voltage of a solar cell or a photovoltaic generator.
- **Short circuit current  $I_{cc}$ :** Corresponding to the current delivered by the cell when the voltage at its terminals is zero.
- **$I_{pm}$ :** Current at the maximum operating power of the photovoltaic cell.
- **$V_{pm}$ :** Voltage at the maximum operating power of the photovoltaic cell.
- Between these two values, there is an optimum giving the greatest power ( $P_{mpp}$  that the cell can provide, which is associated with a maximum voltage  $U_m$  and a maximum intensity  $I_m$ ).
- **Form factor  $FF$ :** Using the current-voltage characteristic of a cell in the dark and under illumination, it is possible to evaluate the performance and the electrical behavior of the photovoltaic cell, therefore the form factor ( $FF$ ) which is defined. as the ratio between the maximum power and the product ( $I_{cc} , V_{co}$ ); from where it is given by the relation:

$$FF = \frac{P_{max}}{I_{CC} \times V_{CO}} = \frac{I_m \times V_m}{I_{CC} \times V_{CO}} \tag{I.7}$$

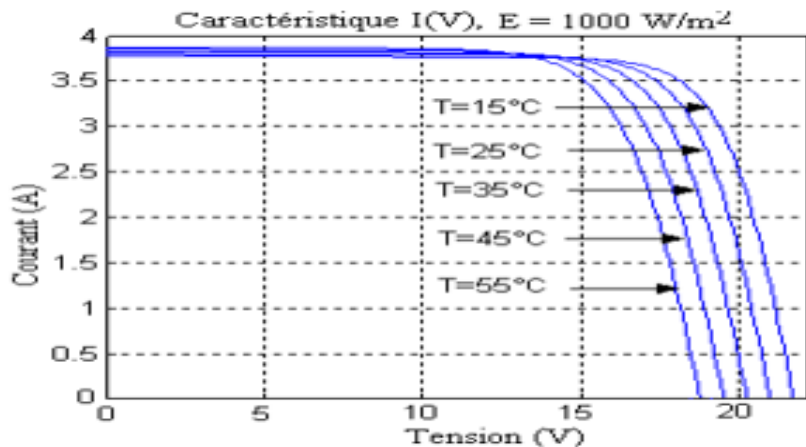
The form factor between 0 and 1, expressed in %, qualifies the more or less rectangular shape of the I-V characteristic of the solar cell. If this was square the form factor would be equal to 1, the power  $P_m$  will be equal to  $I_{CC} \times V_{CO}$ . But generally, the form factor takes values between 0.6 and 0.85 [15].

**1.8.2.3 Influence of Temperature and Illumination**

The pattern of the current-voltage characteristic (Figure (I.6), Figure (I.7)) varies according to the environmental conditions (illumination and temperature).

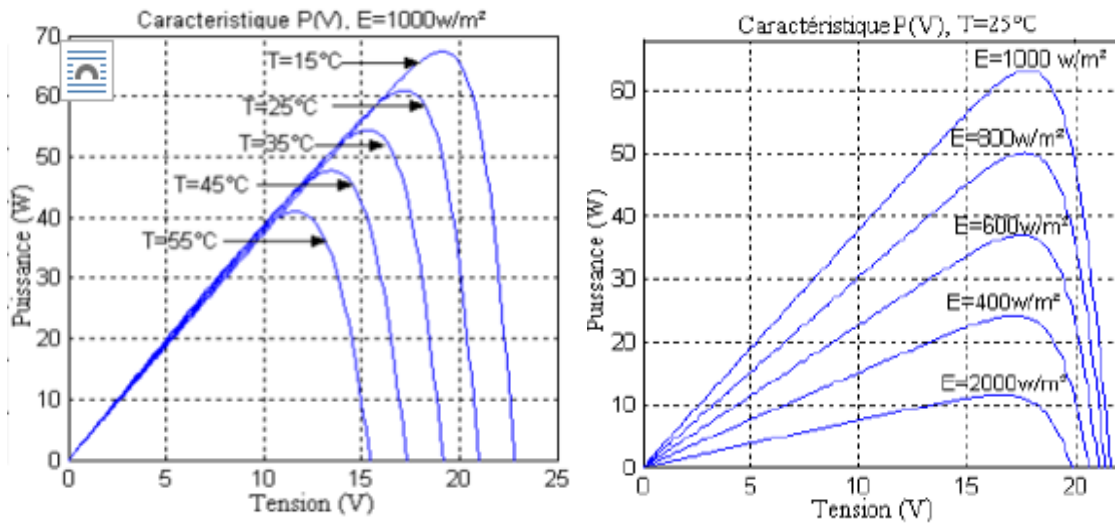


**Fig.I. 6:** Influence of light on current-voltage characteristics of a photovoltaic cell.



**Fig.I.7:** Influence of temperature on current-voltage characteristics of a photovoltaic cell.

The influence of temperature is significant on the current/voltage characteristic. The open-circuit voltage decreases with the temperature increase, but the current varies very little with temperature. Therefore the maximum power (Figure (I.8)) delivered by the photovoltaic cell decreases.



**Fig.I.8:** Influence of temperature on the power-voltage characteristic of a cell photovoltaic.

Unlike the variation in temperature, the variation in illumination affects the short circuit current that decreases as the illuminance decreases. The open-circuit voltage is not sensitive to this variation.

**1.8.2.4 Cell conversion efficiency**

It is defined as the ratio between the maximum power produced by the cell and the power of the solar radiation, which arrives on the cell. If S is the surface area of the cell (in m²) and E is the irradiance-irradiance (in W / m²). Energy efficiency is written [16]

$$\eta = \frac{P_m}{P_{inc} \times S} \tag{I.8}$$

P<sub>inc</sub> : Incident power .

S : Surface of the photovoltaic cell .

1.8.2.5 Equivalent circuit

Numerous mathematical models have been developed in the literature, the aim is to obtain the current-voltage characteristic for the analysis and evaluation of the performance of photovoltaic systems.

The most cited model in the literature is the one-diode model.

a. Ideal PV photovoltaic cell

This is the simplest model used to represent the solar cell, including an  $I_{ph}$  current source, which models the photoelectric current, associated with a diode in parallel which models the P-N junction whose polarization determines the voltage.

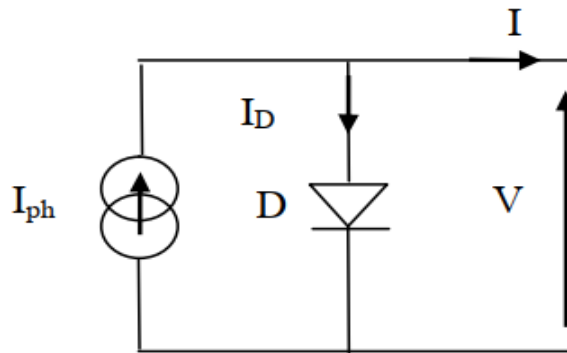


Figure I. 9 : Ideal PV-cell equivalent-circuit models: single-diode model.[18]

Equivalent characteristic equation of an ideal photovoltaic cell is given by:

$$I = I_{ph} - I_D \tag{I. 9}$$

$I_D$  : the current across the diode, it is given by the following relation :

$$I_D = I_s \left( \exp \left( \frac{-V}{A \cdot V_T} \right) - 1 \right) \tag{I. 10}$$

Where:

$I_{ph}$  : Is the photocurrent, the current source, represents charge carrier generation in the semiconductor caused by incident radiation (A);

$I_s$  : Is reverse saturation current of the diode (A) ;

I and V are the delivered current and voltage, respectively (V);

$V_T$  : Is thermic voltage ;

$$V_T = \frac{k_b \cdot T_j}{q} \tag{I. 11}$$

A : Is the recombination factor closeness to an ideal diode (  $1 < A < 1.5$  ) ,

K : Is Boltzmann constant ( $1.38 \cdot 10^{-23}$  Joules/Kelvin).

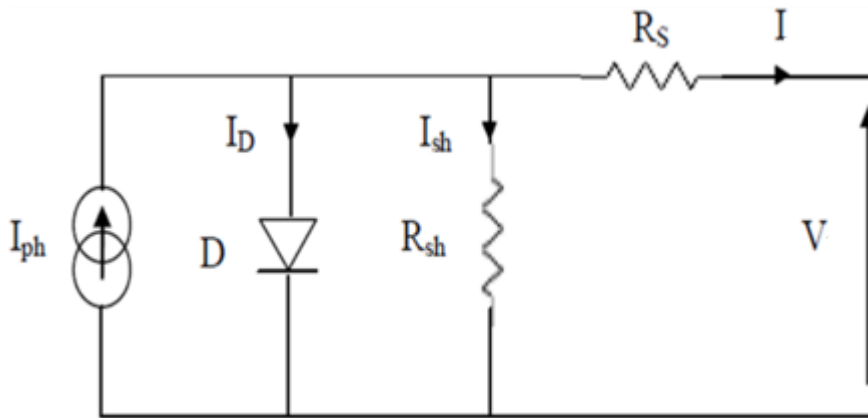
$T_j$ : the cell temperature in Kelvin.

q: Is the electron charge= $1,6 \cdot 10^{-19}$ C.

The maximum efficiency, in the same place, is obtained when the solar radiation is perpendicular to the catchment area, that is to say, the angle of incidence of the radiation on the cell is  $90^\circ$ . [17]

**a. Model of a real cell**

This model takes into account the parasitic resistive effects due to the manufacturing, it involves a current generator for the modeling of the incident luminous flux, a diode for the physical phenomena of polarization and two resistors (series and shunt), as shown in the schematic in Figure (I.10). [4]



**Figure I.10:** PV-cell equivalent-circuit models: single-diode model.[19]

$R_{sh}$  : the shunt resistor, signifies high-current paths through the semiconductor along mechanical defects and material dislocations. ( $\Omega$ ).

$R_s$  : The series resistor, embodies series resistance in the outer semiconductor regions, primarily at the interface of the semiconductor and the metal contacts . ( $\Omega$ ).

The current generated by the PV cell is given by the mesh law:

$$I = I_{ph} - I_D - I_{rsh} \tag{I.12}$$

The current of the shunt resistor is given by :



$$I_{sh} = \frac{V_D}{R_{sh}} = \frac{V + R_s \cdot I}{R_{sh}} \quad (I. 13)$$

The current generated by the cell is described as follows :

$$I = I_{ph} - I_s \times \left( \exp \left( \frac{q \times (V + R_s \cdot I)}{A \times k_b \cdot T_j} \right) - 1 \right) - \left( \frac{V + R_s \cdot I}{R_{sh}} \right) \quad (I. 14)$$

## **I.9 Conclusion**

In this chapter, we have presented some notions on solar radiation and the various parameters involved in the calculations. We have described the operating principle of a PV cell and its main characteristic (current-voltage) finally we carried out modeling of a photovoltaic generator.

**CHAPTER II**  
**METEOROLOGICAL PARAMETERS**

## II.1 Introduction

Meteorology is based on regular observation of meteorological phenomena and the study of the laws governing atmospheric gases, their changes of state, and their movements.

The main factors observed are atmospheric pressure, temperature, humidity, sunshine duration, wind, precipitation and clouds.

The captures allow the translation of physical quantities (temperature, speed, humidity... etc.) into measurable electrical quantities (voltage, currents, frequency, ...etc.).

## II.2 Meteorological parameters

We are interested in the parameters that can have a relation with the illumination arriving on the photovoltaic panel and its output: temperature, atmospheric pressure, relative humidity of the air, and insolation.

### II.2.1 Temperature

Temperature is one of the parameters that describe the state of a system, it is a macroscopic property that expresses the state of agitation or disorder motion of particles, it is therefore related to the kinetic energy of those particles.

The international unit for temperature is Kelvin (K). Another very common unit is Celsius (degrees Celsius). The lowest temperature of the Celsius system is (- 273.15 ° C) corresponding to (0 K). Some Anglo-Saxon countries and the United States use another unit: the degree Fahrenheit (° F). [20].

Les formules de transformations entre les unités sont les suivantes :

$$^{\circ}\text{C} = 0.55 \times (^{\circ}\text{F} - 32) \quad (\text{II. 1})$$

$$\text{K} = ^{\circ}\text{C} + 273.15 \quad (\text{II. 2})$$

The most widely used temperature sensors are:

#### II.2.1.1 Thermocouple

The measuring principle with a thermocouple is two metals A and B, of different nature, connected with two junctions (forming a thermocouple) at a temperature T1 and T2, the thermocouple generates a potential difference which depends on the temperature difference between T1 and T2. For an unknown temperature, one of the two junctions must be maintained at a fixed temperature. So the temperature measurement is an indirect one since the thermocouple

measures the electric potential difference. It is necessary to know the thermocouple used response to be able to link the difference in the electric potential to the temperature difference. [21]

### **II.2.1.2 Thermistance**

They are sensors with a resistance that changes enormously when the temperature varies. There are two types of thermistance:

The CTN thermistances are resistances with negative temperature coefficients, the resistance in a thermistance is determined in function of the temperature.

These are thermistances that can measure a temperature that can go until 300 degrees.

The CTP thermistances are resistances with positive temperature coefficients.

### **II.2.1.3 Transistor and semiconductor thermal sensor**

When the collector of a transistor is traversed by a constant current, it creates a voltage at its terminals. This sensor integrates the components of the power circuits (amplifiers, current source).

We express the voltage between the base and the emitter by the following equation:

### **II.2.1.4 Thermopile**

Thermophile sensors are infrared systems composed of several thermocouples connected in series. These thermocouples are often in the form of circles or lines. We express the thermal energy

### **II.2.1.5 Quartz thermal sensors**

These sensors are based on the oscillation properties of quartz. The frequency is therefore very sensitive to temperature variation. The accuracy of these sensors varies from 0.1 to 0.01 degrees.

They are used in application areas where the temperature varies between -80 and 250 degrees. [22]

Currently, research is able to estimate the temperature from satellite images and algorithms based on artificial intelligence.

**II.2.2 Pressure**

Pressure is a fundamental physical concept. Atmospheric pressure is the pressure of air at any point in an atmosphere. It has long been measured in millimeters of mercury (mm Hg) due to the common use of mercury column barometers. After the adoption of the pascal as a unit of pressure, meteorologists use a multiple of this unit, the hectopascal (1 hPa = 100 Pa). On average, at sea level, the atmospheric pressure is around 1,013.25 hectopascals (hPa). [23]

The pressure is a very important quantity in the chain of measurement, detection, and control, it aims to study a medium that can be either a gas or a fluid.

**II.2.2.1 Piezoelectric pressure sensor**

Piezoelectric pressure sensors are based on the piezoelectric effect. This effect, which can be direct or indirect, was discovered by the Curie brothers in 1880. The application of mechanical stress to a piezoelectric material (quartz by example), leads to the appearance of an electric polarization proportional to the force applied. In 1881, the opposite effect was discovered by Lippmann. Applying voltage electrical to a piezoelectric material causes the appearance of mechanical deformation of the piezoelectric material which is proportional to the applied voltage. The pressure detection of a piezoelectric pressure sensor is done by the electrical voltage measurement.

The membrane that constitutes the test body deforms under the effect of applied pressure. The piezoelectric material transforms this deformation into a voltage variation.

**II.2.2.2 Piezoresistive pressure sensor**

The pressure detection of a piezoresistive pressure sensor is done by measuring a variation in resistance. The advantages of this sensor are good precision, low non-linearity, simple associated electronics. These types of sensors are extremely sensitive to temperature and require a specific compensation circuit, which considerably increases their unit cost price.[24]

The membrane which constitutes the test body deforms under the effect of applied pressure. The piezoresistive gauges ensure the transformation of this deformation into a variation of resistance. The Wheatstone bridge makes it possible to translate this variation in resistance into electrical voltage.

### II.2.2.3 Capacitive pressure sensor

The pressure detection of a capacitive pressure sensor is done by measuring a change in capacitance. The advantages of this sensor are high-pressure sensitivity and low-temperature sensitivity. The membrane which constitutes the test body deforms under the effect of applied pressure. The metal reinforcements ensure the transformation of this deformation into a variation in capacitance. The electronic processing and measurement circuit transforms this variation in capacitance into electrical voltage.[24]

### II.2.3 Humidity sensors

Due to the asymmetric distribution of their electric charge, water molecules are easily absorbed on almost any surface, where they are presented as a monolayer or multimolecular. Water vapor in air or any other gas is generally called humidity; in liquids and solids, it is usually indicated as humidity. The determination of humidity, such as in the prediction of floods, fog, conditions for the appearance of plant diseases, etc., is of great economic importance. Products food or stored raw materials may dry out at low humidity or become moldy in high humidity. In many industrial processes, the measurement of humidity is important for the maintenance of optimal manufacturing conditions. Humidity can be expressed in several ways, and there are a lot of methods to measure them. An engineer whose main concern is to avoid condensation anywhere in his system must be interested in the dew point of the gas flow. A chemist can be interested in the only quantity of water vapor, while in a printing house or a chamber of storage, relative humidity is more than important.

#### II.2.3.1 Capacitive humidity sensors

The principle of detection of a capacitive humidity sensor, based on the measurement of the dielectric constant of the sensitive layer, will vary with the adsorption of water molecules by this layer. This variation of the dielectric constant or permittivity  $\epsilon_r$  induces a variation in capacity which is directly measurable.

Remembering that water has a dielectric constant, high value (80.1). It causes once absorbed into the film strong variations in capacity. It is for this reason that the majority of polymers used for capacitive humidity sensors have an electrical permittivity lower than that of water such as polyimide (polyamide) films, cellulose acetate, and keratin which have relative dielectric

permittivity values of 3, 6, and 8 respectively. There are two main aspects to moisture sensor studies:

- ✓ The configuration of the electrodes arranged to generate an electric field.
- ✓ The hygroscopic properties of the sensitive material.

### **II.2.3.2 Interdigital sensors**

Interdigital electrodes (IDE) are widely used due to their simplicity in manufacturing and easy integration with other circuits. It also allows maximizing the detection surface in direct contact with the environment to be characterized.

Added to this another important advantage is the possibility of measuring both the capacity and resistance. Interdigitated electrode sensors are found in different applications such as surface acoustic wave (SAW) devices, detectors photosensitive, the design of microwave filters, humidity sensors and gas, biosensors for biological detection, or as a back contact interdigitated for photovoltaic cells. The principle of the coplanar electrode sensor follows the following rule: a planar capacitor with two parallel plates where the electrodes open to form a single side for access to the material under test. The voltage applied between the positive and negative electrodes creates an electric field between each pair of electrodes. When the active layer is deposited on the sensor, the lines of electric fields that are created to bend and penetrate the material under test changing the impedance of the sensor. Therefore, the dielectric properties of the material, as well as the geometry of the electrodes, affect the capacitance and the conductance between the two electrodes. [25]

### **II.2.3.3 Resistive humidity sensors**

Among the different types of humidity sensors developed, resistive sensors have received much attention because of their advantages such as high sensitivity, quick response, easy preparation, and low cost. In addition, these resistive humidity sensors are devices that convert humidity in the air by a change in impedance. This can be measured by current, voltage, or resistance.

There are three groups of sensitive layer materials that are of particular importance: ceramics, polymers, and electrolytes. Research on sensors is mainly based on forming sensitive films to improve their durability and stability in a humid environment.

According to the literature, most resistive sensors consist of a ceramic as the sensitive layer. The structures of resistive sensors are often comparable to capacitive probes, i.e. a planar IDE-

based device. Resistive sensors are based on the variation of the real part of the impedance with relative humidity (RH).

#### **II.2.3.4 Hair hygrometer**

This principle is historically the first used to assess the ambient humidity level. Transduction is based on the deformation of a hair after absorption of moisture. The absorption of moisture causes a swelling effect of the hair which results in essentially a variation in length which is transmitted to a needle or a point recording by special transmission. Organic fibers are also used in place of hair. The advantage of this transduction technique is that it is not subject to drift in temperature, the material is generally reliable over a long period.

#### **II.2.3.5 Condensation hygrometer**

A condensing hygrometer has a small mirror that is constantly cooled by the effect Peltier in front of a humid air sample until fine water droplets appear on its surface. At this moment, the liquid phase (and/or solid) is in equilibrium with the water vapor in the air. We measure the dew temperature and deduce the rate of humidity.

Gravity sensors:

The principle of transduction is based on the variation in the mass of an exposed sensitive layer to a change in humidity. These sensors generally use microbalance quartz to detect the change in mass. The measurement is then carried out by measuring the variation resonance frequency of quartz, a piezoresistive material, excited by an electrical signal.

#### **II.2.4 The wind**

Wind refers to the movement of air. It arises when there is a pressure difference between two points. Air flows from where the pressure is highest to where it is lowest. In the language of meteorologists, the air is said to move from high pressure (anticyclones) to low pressure (lows).

The direction and speed of the wind are measurable quantities whose knowledge is necessary for the study of the dynamics of air masses. The direction indicates where the wind is blowing.

Its units are either the cardinal points (N, S, E, W) or degrees centigrade. Speed is expressed either in meters per second (m / s), or kilometers per hour (km / h) or in knots.



1 knot corresponds to a distance of 1 nautical mile covered in 1 hour, i.e. 1.852 km / h, 1 m / s is equivalent to 3.6 km / h and approximately 2 knots. [23]

#### **II.2.4.1 Wind formation**

Wind and pressure are strongly linked. The origin of the winds is related to the difference in the distribution of atmospheric pressure. These variations are mainly due to an uneven distribution of solar energy received at the earth's surface, and to differences in the thermal properties of the surfaces of continents and oceans.[26]

#### **II.2.4.2 Wind speed**

Currently, the instrument used to measure wind speed is the anemometer. The latter has different types that they have developed over time. To carry out speed measurements, it is preferable to place it on a ten meter mast according to the criteria of the World Meteorological Organization because of the obstacles that can disrupt the air flow. But it is also possible to use hand-held anemometers, without support to have the value of the speed in a very precise place. [26]

### **II.2.5 Precipitation**

#### **II.2.5.1 Definition of precipitations**

Are called precipitation, all meteoric water that falls on the surface of the earth, both in liquid form (drizzle, rain, downpour) and solid form (snow, sleet, hail) and deposited or occult precipitation (dew, hoarfrost). , frost, ...). They are caused by a change in temperature or pressure. Precipitation is the only "entry" to the main continental hydrological systems, which are watersheds.

#### **II.2.5.2 Precipitated water depth measurements**

As precipitation varies according to different factors (displacement of the disturbance, location of the downpour, the influence of topography, etc.), its measurement is relatively complicated.

Regardless of the form of precipitation, liquid or solid, we measure the amount of water that has fallen over a certain period. It is generally expressed in height of precipitation or layer of the water precipitated per unit of horizontal area (mm). Its intensity (mm / h) is also defined as the

height of water precipitated per unit of time. The accuracy of the measurement is at best of the order of 0.1 mm. In Switzerland, any precipitation greater than 0.5 mm is considered effective rain.

The two fundamental devices which allow the measurement of precipitation are:

- ✓ **The rain gauge:** a basic instrument for measuring liquid or solid precipitation. It indicates the total quantity of water precipitated and collected inside a calibrated surface in a time interval between two readings.
- ✓ **The pluviograph:** An instrument capturing precipitation in the same way as the rain gauge but with a device making it possible to know, in addition to the total water height, their distribution over time, in other words the intensities.

## II.2.6 Insulation measurement

Sunshine duration during a given period is defined as the sum of the time for which the direct solar irradiance exceeds  $120 \text{ W m}^{-2}$ .

### II.2.6.1 Campbell-stokes heliograph

It consists of a glass sphere 10 cm in diameter, which concentrates the rays sunglasses on a strip of cardboard placed on a concentric frame. Depending on the intensity of solar radiation received, the image of the sun moving on the diagram causes a burning, browning, or discoloration. The length of the trace on the cardboard strip represents the duration of sunstroke. The energy required for burning is of the order of  $120 \text{ W / m}^2$ . [27]



**Figure II.1:** Campbell-stokes heliograph.

### II.2.6.2 Fiber optic heliograph:

It is in the form of a cylinder whose axis is parallel to the north pole-pole axis. South. A cylindrical glass window lets indirect solar radiation which is intercepted by an optical fiber bent at 90 ° and driven by a continuous rotational movement around the axis of the sensor.

When, during its rotation, the free part of optical fiber provided with the diaphragm is oriented towards the solar disk, it conducts direct solar radiation intercepted on a fixed detector aligned with the other end of the fiber.



**Figure II.2 :** Fiber optic heliograph. [28]

### II.3 Global solar irradiation models

Several methods, which use different weather parameters, have been developed around the world to estimate the global solar radiation. Angstrom [29] developed the first model which was modified by Prescott in 1940 using only the relative duration of sunshine and extra-terrestrial radiation. [30] Many researchers have used this model to establish empirical correlations [31-32]. Others have found that the model's regression coefficients are site dependent and have proposed regression coefficients based on certain geographic factors, such as latitude, altitude, etc. [33-34]

Other empirical models have been developed to calculate solar radiation using not only sunshine duration, extra-terrestrial radiation and geographic parameters, but also using meteorological parameters. Hargreaves and Samani developed a temperature-based model using maximum and minimum temperature data to estimate the global solar radiation, Meenal, *et al.*, [35], Pandey and Katiyar [36], Bristow and Campbell [37], and Allen [38] have used the temperature data to estimate global solar radiation from different location in the world. The Maghrabi model [39] which involves five parameters including perceptible water vapor calculated from the dew point temperature.

As the availability of meteorological parameters, which are used as the input of radiation models is the most important key to choose the proper radiation models at any location, empirical models can be mainly classified into four following categories based on the following employed meteorological parameters and a brief description of mathematical expression of few models examined are given below.

#### II.3.1 Sunshine-based models.

The most commonly used parameter for estimating global solar radiation is sunshine duration. Sunshine duration can be easily and reliably measured, and data are widely available at the weather stations. Most of the models for estimating solar radiation that appear in the literature only use sunshine ratio ( $S/S_0$ ) for prediction of monthly average daily global radiation.[40][41][42]

##### a. Angstrom–Prescott model

The first and the most widely used correlation for estimating monthly average daily global solar radiation was proposed by Angstrom, who derived a linear relationship between the ratio of average daily global radiation to the corresponding value on a completely clear day ( $H/H_c$ ) at a

given location and the ratio of average daily sunshine duration to the maximum possible sunshine duration.

$$\frac{H}{H_c} = a + b \left( \frac{S}{S_0} \right) \quad (\text{II. 1})$$

A basic difficulty with Eq. (II. 1) lies in the definition of the term  $H_c$ . Prescott and the others have modified the method to base it on extraterrestrial radiation on a horizontal surface rather than on clear day radiation and therefore proposed the following relation:

$$\frac{H}{H_0} = a + b \left( \frac{S}{S_0} \right) \quad (\text{II. 2})$$

### b. Page model

Page has provided the coefficients of the modified Angstrom-type model, which is claimed to be applicable anywhere in the world:

$$\frac{H}{H_0} = 0.23 + 0.48 \left( \frac{S}{S_0} \right) \quad (\text{II. 3})$$

### c. Newland model

A linear-logarithmic model, has been used by Newland to obtain the best correlation between  $(H/H_0)$  and  $(S/S_0)$ :

$$\frac{H}{H_0} = a + b \left( \frac{S}{S_0} \right) + c \log \left( \frac{S}{S_0} \right) \quad (\text{II. 4})$$

### d. Ogelman et al. model

model Ogelman et al. expressed the ratio of global to extraterrestrial radiation by a second order polynomial function of the ratio of sunshine duration:

$$\frac{H}{H_0} = a + b \left( \frac{S}{S_0} \right) + c \left( \frac{S}{S_0} \right)^2 \quad (\text{II. 5})$$

### e. Samuel model

Samuel has correlated  $(H/H_0)$  with  $(S/S_0)$  in the form of a third order polynomial equation:

$$\frac{H}{H_0} = a + b \left( \frac{S}{S_0} \right) + c \left( \frac{S}{S_0} \right)^2 + \left( \frac{S}{S_0} \right)^3 \quad (\text{II. 6})$$

### II.3.2 Cloud-based models.[40][41][42]

- a. Badescu model
- b. Modified Daneshyar model (Sabziparvar model)

### II.3.3 Temperature-based models.

- a. Hargreaves model

Hargreaves and Samani recommended a simple equation to estimate solar radiation using only maximum and minimum temperatures :

$$\frac{H}{H_0} = a(T_{max}-T_{min})^{0.5} \quad (II. 7)$$

Initially, coefficient a was set to 0.17 for arid and semi-arid regions. Hargreaves later recommended using a=0.16 for interior regions and a=0.19 for coastal regions. [40][41][42][43]

### II.3.4 Other meteorological parameter-based models[44][45][46]

- a. Swartman and Ogunlade model

Swartman and Ogunlade stated that the global radiation can be expressed as a function of the S=S<sub>0</sub> ratio and mean relative humidity (RH) :

$$\frac{H}{H_c} = a \left( \frac{S}{S_0} \right)^b RH^c \quad (II. 8)$$

$$\frac{H}{H_c} = a + b \left( \frac{S}{S_0} \right) + cRH \quad (II. 9)$$

- b. Gophanthan and abdalla models

introduced a multiple linear regression equation of the form:

$$\frac{G}{G_0} = a + b \cos \phi + ch + d \left( \frac{S}{S_0} \right) + eT + fR \quad (II. 10)$$

The model in Eq. (II.1) modified for Bahrain is written as:

$$\frac{G}{G_0} = a + b \left( \frac{S}{S_0} \right) + cT + dRH \quad (II. 11)$$

And

$$\frac{G}{G_0} = a + b \left( \frac{S}{S_0} \right) + cT + dR + ePS \quad (\text{II. 12})$$

where  $G_0$  is the extraterrestrial radiation,  $h$  is the elevation of the location in kilometers above sea level,  $T$  is the monthly mean daily maximum temperature,  $R$  is the daily mean relative humidity as a percentage, and  $P$  is the ratio between mean sea level pressure and mean daily vapour pressure.[40][41][42]

## II.4 Conclusion

The purpose of meteorological measurements is to quantify the various quantities that characterize the physical and thermodynamic state of the atmosphere.

In this chapter, we have presented notions on the different meteorological factors (temperature, atmospheric pressure, relative humidity of the air, and insolation.

Moreover, we saw their measuring tools in general. Finally, we have given the different existing model categories and few examples of those models.

## **CHAPTER III**

# **SOLAR RADIATION MODELING IN THE FUNCTION OF METEOROLOGICAL PARAMETERS**



### **III.1 Introduction**

The global knowledge of solar radiation is of utmost importance to all energy conversion systems. Its reliance on meteorological parameters is not always well known. The solar radiation value is not available for many countries that do not have the necessary measuring equipment and techniques, and for that, it is important to develop new methods to estimate the solar radiation value using the available meteorological parameters.

The objective of our work is to develop a model for predicting the evolution of solar irradiation as a function of some meteorological parameters for the region of Bejaia. These geographic coordinates are: Latitude  $36^{\circ} 45'21''$  North and Longitude  $55^{\circ} 05'03''$  East.

### **III.2 Changes in meteorological data**

Time represents the state of the atmosphere in a particular place at a particular point in time. It varies from moment to moment, and from place to place. The climate is the “average” of various types of weather. When studying the climate of a region, we perform generally averages over certain fixed periods of certain meteorological variables, namely air temperature, humidity air, precipitation, wind strength and direction, sunstroke and intensity of solar radiation, etc. Climatological studies are based on observation at every place on the globe and every moment of one of these weather variables. [44]

### **III.3 Selection of data**

The data used in this work are the daily global solar radiation on a horizontal surface  $H$ , sunshine hours, ambient temperature, air pressure and relative humidity. These data are available from 1999 to 2001 at the National Aeronautics and Space Administration (NASA) website. [45]

The extraterrestrial solar irradiation was calculate according to the equations (I.1).

We were able to build a database over a period of three years (1999 to 2001) composed of 1010 examples.

The measured data during 1999 – 2001 are divided into two periods: The first period (01/01/1999 to 31/12/2000) was used to develop some models, while the second dataset (01/01/2001 to 31/12/2001) are used in order to value the performances of the models obtained.

III.4 Evolution of meteorological data

The coming figures III.1, III.3, III.4, and III.5 respectively show the changes in the monthly averages of irradiation and meteorological parameters (ambient temperature, relative humidity, atmospheric pressure and insolation) during the year 1999.

III.4.1 Global irradiation

The figure (III.1) shows that the average monthly global irradiation varies from 1.93 KWh/m<sup>2</sup>/d during the month of December to around 7.55 KWh /m<sup>2</sup> /d during the month of July. Solar energy is therefore available in Bejaïa throughout the year, but with amounts that depend mainly on the season. The annual average of the global radiation during the year 1999 is 4.70 KWh/m<sup>2</sup> /d.

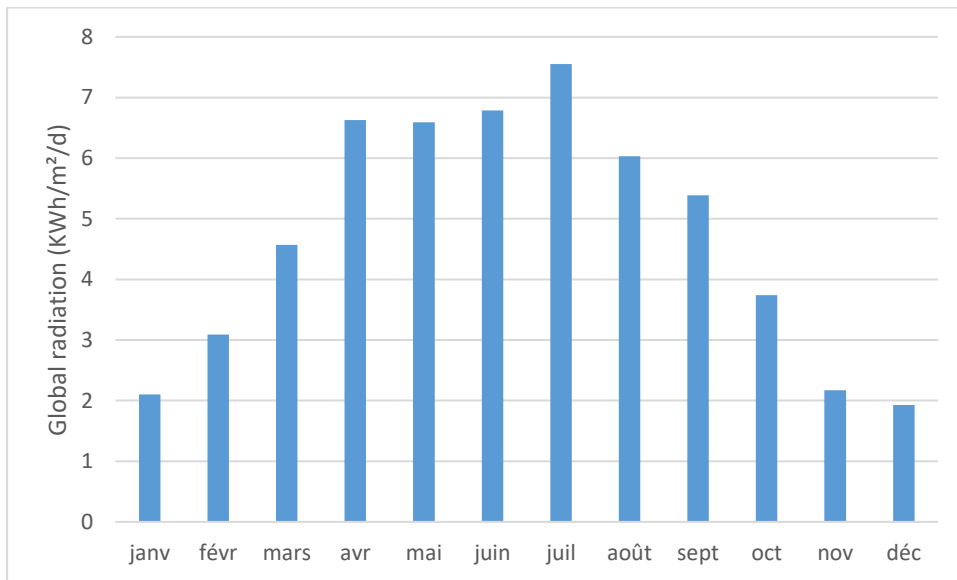
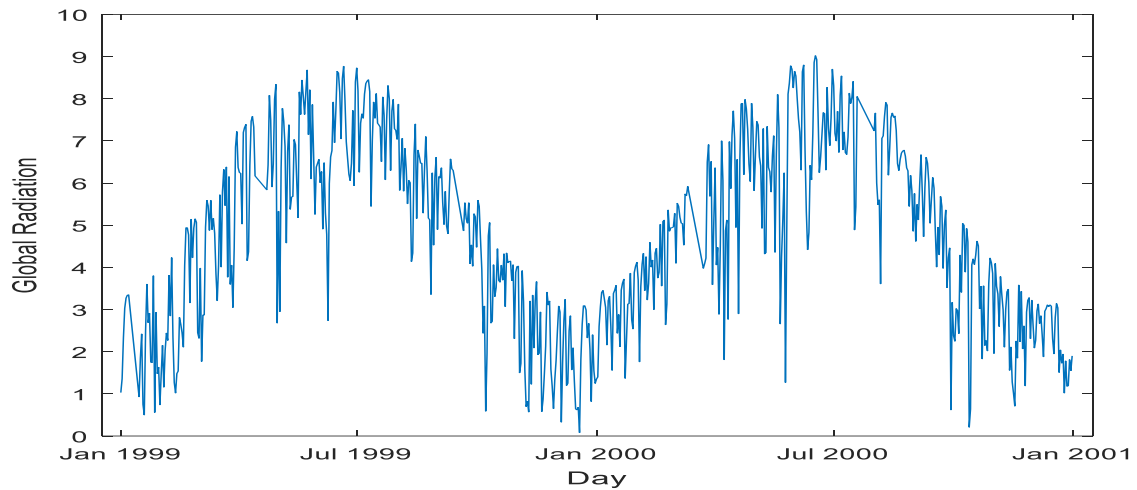


Figure III.1: Global radiation (KWh /m<sup>2</sup>/d) during the year1999 in Bejaia.

The mean daily evolution of global solar radiation received on a horizontal surface in the period 1999- 2000 are shown in figure III.2.



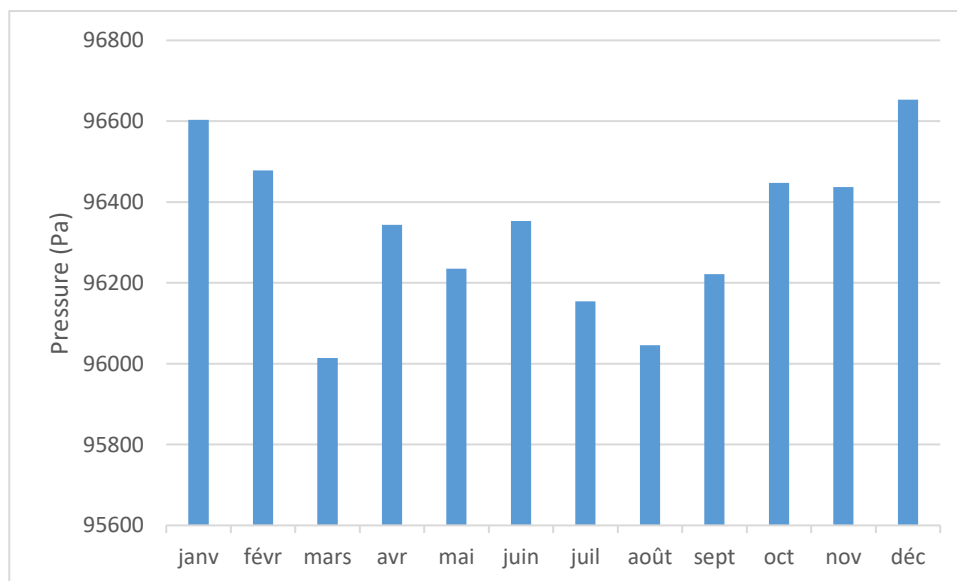
**Fig. III.2:** Daily evolution of global horizontal radiation for the period: 1999-2000

### III.4.2 Insolation

Solar insolation also varies in the same direction as the global irradiation. It is higher in the dry season than in other seasons. In summer, the sky is relatively clear and during the other seasons (autumn, winter and spring), the sky becomes more overcast.

### III.4.3 Pressure

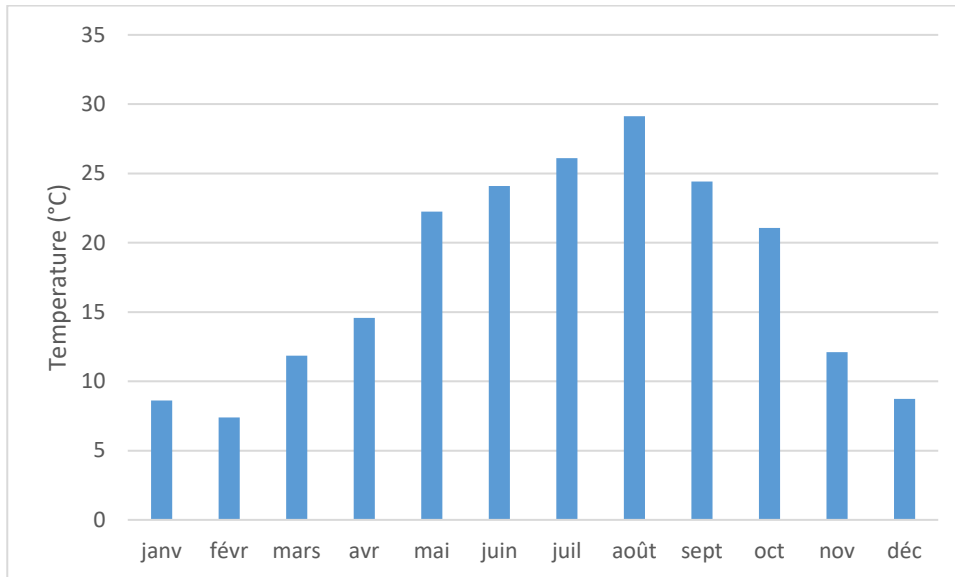
The maximum pressure value appears in December, while the minimum value is in March. Its annual average during the year 1999 is 96,31 KPa.



**Figure III.3:** Pressure (Pa) during 1999 in Bejaia.

### III.4.4 Temperature

In 1999, the maximum value of monthly average of the temperature appeared in August (29,14 °C), while the minimum value is in February (7.39 °C). The annual average temperature during the year 1999 is 17.60 °C.



**Figure III.4:** Temperature (°C) during 1999 in Bejaia.

### III.4.5 Relative humidity RH (%)

Since the city of Bejaia is situated near the mediterranean sea , it is very humid. The lowest monthly average exceeds 40% . Its annual average during the year 1999 is 57,37 %.

We note that the rate of change in humidity is the reverse of that of temperature.

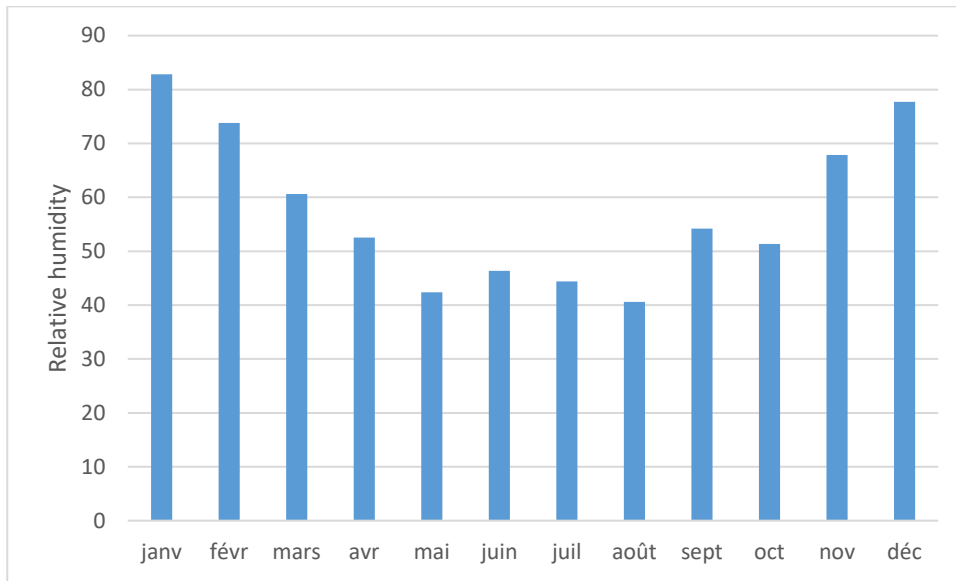


Figure III.5: The humidity relative during 1999 in Bejaia.

III.5 Performance criteria

However, a simple visual analysis of the results of a simulation is not an objective assessment of the model. Indeed, the human eye is not able to see all the differences that may exist between two curves of similar general appearance. So we need to equip ourselves with objective criteria to compare simulations with observations. And we will be using 2 of performance criteria:

a. Root Mean Square Error (RMSE)

The measurement of the mean square error (RMSE) is a criterion often used to measure the difference between the observation and the simulation, in particular giving an idea of the dispersion between the two. The lower it is, the smaller the difference between the observations and the simulation will be.

$$RMSE = \left( \frac{\sum_{i=1}^N (H_{i,m} - H_{i,c})^2}{N} \right)^{1/2} \tag{III. 1}$$

Such that:  $H_{i,m}$  is the irradiation measured on day  $i$ .

$H_{i,c}$  is the overall irradiation calculated on day  $i$ .

$N$ : number of measurement points

b. Mean Bias Error (MBE)

The mean bias error (MBE) measures the tendency of the model to underestimate or overestimate observations.

$$MBE = \left( \frac{\sum_{i=1}^N H_{i,m} - H_{i,c}}{N} \right) \quad (III. 2)$$

A positive MBE represents an overestimation, while a negative MBE shows an underestimation.

A low MBE is desired. The smaller value of RMSE, the better is the model's performance.

### III.6 Proposed empirical models

#### III.6.1 Linear regression models

In order to find the right model for Bejaïa city, we tried models with 2, 3 and 4 parameters. Multiple linear regression analyses of the parameters (S/S<sub>0</sub>, T, P, RH) used in different combinations, yielded several relationships to estimate global solar irradiation. These were processed and analyzed using a Matlab program to obtain the correlations and regression coefficients by the least squares method. The relationships with the highest correlation coefficient were selected.

In the case of a single variable, the highest correlation coefficient was obtained for the relation containing S/S<sub>0</sub>, we obtain model 1:

$$\frac{H}{H_0} = a + b \frac{S}{S_0} \quad (III. 3)$$

$H_0$  is calculated by relation I.1.

The insolation  $S_0$  outside the atmosphere is calculated by the next relation:

$$S_0 = \frac{2 \times \omega_s}{15} \quad (III. 4)$$

With  $\omega_s$  given by the equation I.3.

The calculated values were compared to the measured values in each regression relation through correlation coefficients R. [42]

$$R = \frac{\sum_{i=1}^N (H_{i,m} - \overline{H_m})(H_{i,c} - \overline{H_c})}{\{[\sum_{i=1}^N (H_{i,m} - \overline{H_m})^2] [(H_{i,c} - \overline{H_c})^2]\}} \quad (III. 5)$$

Where:

N is the number of points of measure;  $H_{i,c}$  the calculated values of global solar radiation calculated on the day i ;  $H_{i,m}$  the measured values of global solar radiation on the day i.

For the relations with two variables the highest correlation coefficient was obtained for the relation containing  $S / S_0$ , RH, we obtain model 2:

$$\frac{H}{H_0} = a + b \frac{S}{S_0} - c \text{RH} \quad (\text{III. 6})$$

For relations with three variables the highest correlation coefficient was obtained for the relation containing  $S / S_0$ , RH and T, we obtain model 3:

$$\frac{H}{H_0} = a + b \frac{S}{S_0} + c T - d \text{RH} \quad (\text{III. 7})$$

The fourth linear model, contains all four variables ( $S / S_0$ , T, RH, P) :

$$\frac{H}{H_0} = a + b \frac{S}{S_0} + c T - d \text{RH} + e P \quad (\text{III. 8})$$

### III.6.2 Nonlinear regression models

As we saw earlier, the previous models is linear sunshine based model. In the next section quadratic and cubic sunshine based models will be developed. Then we will introduce other meteorological parameters (ambient temperature, air pressure and relative humidity) for these non-linear models.

These models are defined as:

#### Model 5:

$$\frac{H}{H_0} = a + b \frac{S}{S_0} + c \left(\frac{S}{S_0}\right)^2 \quad (\text{III. 9})$$

#### Model 6:

$$\frac{H}{H_0} = a + b \frac{S}{S_0} + c \left(\frac{S}{S_0}\right)^2 + d \left(\frac{S}{S_0}\right)^3 \quad (\text{III. 10})$$

#### Model 7:

$$\frac{H}{H_0} = a + b \frac{S}{S_0} + c \left(\frac{S}{S_0}\right)^2 + d \text{RH} \quad (\text{III. 11})$$

#### Model 8 :

$$\frac{H}{H_0} = a + b \frac{S}{S_0} + c \left(\frac{S}{S_0}\right)^2 + d \text{RH} + eT \quad (\text{III. 12})$$

#### Model 9:

$$\frac{H}{H_0} = a + b \frac{S}{S_0} + c \left(\frac{S}{S_0}\right)^2 + d \text{RH} + eT + fP \quad (\text{III. 13})$$

#### Model 10:

$$\frac{H}{H_0} = a + b \frac{S}{S_0} + c \left(\frac{S}{S_0}\right)^2 + d \left(\frac{S}{S_0}\right)^3 + e RH \quad (\text{III. 14})$$

**Model 11:**

$$\frac{H}{H_0} = a + b \frac{S}{S_0} + c \left(\frac{S}{S_0}\right)^2 + d \left(\frac{S}{S_0}\right)^3 + e RH + fT \quad (\text{III. 15})$$

**Model 12:**

$$\frac{H}{H_0} = a + b \frac{S}{S_0} + c \left(\frac{S}{S_0}\right)^2 + d \left(\frac{S}{S_0}\right)^3 + e RH + fT + gP \quad (\text{III. 16})$$

### III.7 Results and discussion

Newly empirical coefficient of nonlinear proposed models with the values of their coefficients of correlation (R) are presented in table III.1

**Table III.1:** New coefficient of the models

| Models         | Values of coefficients |         |             |             |            |   |   | R       |
|----------------|------------------------|---------|-------------|-------------|------------|---|---|---------|
|                | a                      | b       | c           | d           | e          | f | g |         |
| <b>Model 1</b> | 0.32361                | 0,99919 |             |             |            |   |   | 0,9998  |
| <b>Model 2</b> | 0,6327                 | 0,999   | -0,004152   |             |            |   |   | 0,9998  |
| <b>Model 3</b> | 0,1866                 | 0,999   | 0,1866      | -0,00002753 |            |   |   | 0,9998  |
| <b>Model 4</b> | -8,3605                | 0,9989  | 0,01326     | -0,0009409  | 0,00008966 |   |   | 0,9998  |
| <b>Model 5</b> | 0.5354                 | 1.0016  | -4.377E-06  |             |            |   |   | 0.99981 |
| <b>Model 6</b> | 3.2498                 | 0.9806  | 4.3448E-05  | 3.2949E-08  |            |   |   | 0.99981 |
| <b>Model 7</b> | 1,3335                 | 1,0011  | -3,9094E-06 | 1,1157E-02  |            |   |   | 0.99981 |
| <b>Model 8</b> | -17,7864               | 0,9620  | 2,7409E-05  | 0,2314      | 0,9620     |   |   | 0.99928 |



|                 |          |        |            |            |            |             |            |         |
|-----------------|----------|--------|------------|------------|------------|-------------|------------|---------|
| <b>Model 9</b>  | -193,041 | 0,9357 | 4,7727E-05 | 2,0333E-03 | 0,9357     | 2,0333E-03  |            | 0.99907 |
| <b>Model 10</b> | 3,6775   | 0,9824 | 3,8531E-05 | -2,9266E-8 | -1,0220E-2 |             |            | 0.99983 |
| <b>Model 11</b> | 4,1082   | 0,9815 | 4,0538E-05 | -3,0620E-8 | -1,3061E-2 | -1,1120E-02 |            | 0.99983 |
| <b>Model 12</b> | 6,7787   | 0,9816 | 4,0442E-05 | -3,0523E-8 | -1,2971E-2 | -1,1277E-02 | -2,7924E-5 | 0.99983 |

The analysis of the results shows that all models give a very good fitting between the daily global radiation and sunshine duration, with higher coefficients of correlation than 0.99.

Using the second part of data (01/01/2001 to 31/01/2001), we calculated statistical indicators to validate the models that we generated using the first part of the data of the years 1999 and 2000.

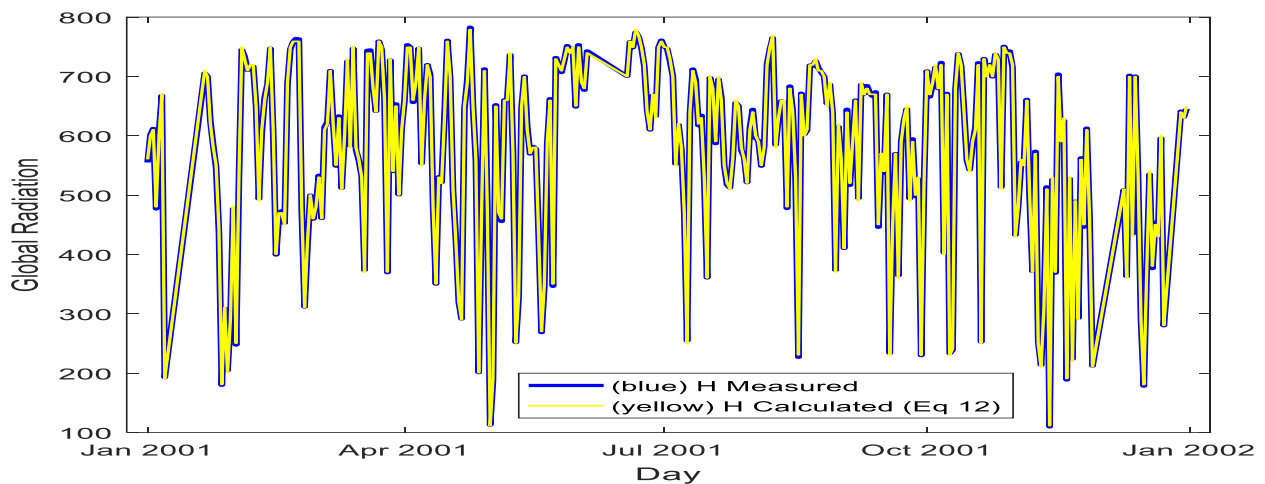
**Table III.2:** Statistical results for the validation (MBE and RMSE).

| <b>Modèles</b>  | <b>MBE</b><br>(MJ/m <sup>2</sup> /j) | <b>RMSE</b><br>(MJ/m <sup>2</sup> /j) |
|-----------------|--------------------------------------|---------------------------------------|
| <b>Model 1</b>  | 2,9809                               | 0,1343                                |
| <b>Model 2</b>  | 2,9768                               | 0,1311                                |
| <b>Model 3</b>  | 2,9800                               | 0,1303                                |
| <b>Model 4</b>  | 2,9805                               | 0,1330                                |
| <b>Model 5</b>  | 8.6679e-05                           | 2.9625                                |
| <b>Model 6</b>  | -1.5084e-04                          | 2.9591                                |
| <b>Model 7</b>  | 1.8647e-07                           | 2.9582                                |
| <b>Model 8</b>  | 1.0288e-07                           | 5.8091                                |
| <b>Model 9</b>  | -5.5563e-09                          | 6.6033                                |
| <b>Model 10</b> | -6.8843e-09                          | 2.9555                                |
| <b>Model 11</b> | 4.6293e-06                           | 2.9550                                |

|                 |             |        |
|-----------------|-------------|--------|
| <b>Model 12</b> | -3.0153e-06 | 2.9550 |
|-----------------|-------------|--------|

According to these results, all proposed models gives close results. RMSE varies from 2,9550 to 6.6033 and MBE, varies from  $-5.5563e-09$  to  $-1.5084e-04$ .

The values of global solar radiation estimated using model 12 are compared with measured values in the next Figure (Figure (III.6))



**Figure III.61:** Comparison between the measured and calculated daily global horizontal radiation by the model 12.

According to figure (III.6), we note that the proposed model (12) is in very good agreement with the values measured data. The maximum difference is quite small.

### III.8 Conclusion

After confronting, the measured values and those estimated by the proposed models, we noted that these models, driven to better results: highest correlation coefficients, the values of mean bias error and root mean square error are in acceptable ranges.

This indicates the validity of using these models to estimate the global solar radiation intensity in Bejaia city.

# *General conclusion*

## **General conclusion**

Quantifying the solar radiation is the data set describing the evolution of the solar radiation at a given place and during a given period. Its study is the starting point of any investigation in the field of solar energy.

The objective of this work was to model solar irradiation as a function of meteorological parameters in Bejaia.

To achieve this objective, first of all, some notions on solar radiation and the various parameters involved in the calculations have been reviewed. The principle of operation as well as the modeling of a photovoltaic cell were discussed.

Second, the operating principles and characteristics of some meteorological sensors were presented along with a few models that already had been given by a few researchers in the domain.

Afterwards, a multiple linear and nonlinear regression was applied to four meteorological data sets, which were : the daily global solar radiation, sunshine hours, ambient temperature, air pressure and relative humidity , used in different combinations, yielded several relationships to estimate global solar irradiation. These were processed and analyzed using a Matlab program to obtain the correlations and regression coefficients.

Using the second part of data (01/01/2001 to 31/01/2001), we calculated statistical indicators to validate the models that we generated using the first part of the data of the years 1999 and 2000.

The global solar radiation estimated from the models was compared with the values measured between January 1999 and December 1999 by calculating statistical indicators to validate the models that we generated.

The agreement between the measured and the computed values is remarkable, and the models are recommended for use in Bejaia city and in any location with similar climatic parameters.

In conclusion, the various global solar irradiation prediction models obtained can be used in the design and performance estimation of solar applications in Bejaia as well as in the optimization and optimal sizing of solar systems,

In perspective, it would be interesting to use artificial intelligence techniques to better optimize the variation model of global solar irradiation as a function of several meteorological parameters.

# *Bibliography*

**Bibliography**

- [1] : A. Khellout, A. Khellout, « Etude et réalisation d'un tracker solaire autopiloté commande via une carte Arduino. Eloued », Mémoire de Master, Université Hamma Lakhdar, 2018.
- [2]: F. Ghisani, « Out Door Experimental Characterization Of A Pv Cell Under High Concentrated Solar Flux », Mémoire de Master, Université Saad Dahleb, 2017.
- [3]: O. Bouguerra, O.Benslimane, « Solar Radiation Prediction Using Machine Learning», Mémoire de Master, Université Mohamed Boudiaf M'sila, 2020.
- [4] : S. HAOUAMED, K. aiadi , « Modélisation Et Optimisation D'un Capteur De Rayonnement Par La Technique D'orientation À Deux Axes Pour Un Panneau Photovoltaïque », Mémoire de Magister , Université Ouergla, Kasdi Merbah , 2013.
- [5] : A. Boutalbi, « Prédiction De Rayonnement Solaire Global Sur Le Plan Horizontal En Fonction De La Pression, Humidité Relative Et De La Température Ambiante »,Mémoire de Master, Université Mohamed Khider Biskra , 2019.
- [6] : M. Akermi, « Modélisation, Simulation Et Analyse Du Comportement D'un Capteur Solaire Plan À Eau Pour Différents Sites En Algerie», Thèse de Doctorat, Université Abou Bekr Belkaid Tlemcen, 2019.
- [7] : A. Mediani, A. Benatallah, « Amélioration Des Performances Et Optimisation D'un Capteur Solaire» , Thèse de Doctorat, Université Ahmed Draia Adrar, 2020.
- [8] : F. Trahi, « prédiction de l'irradiation solaire globale pour la région de tizi-ouzou par les réseaux de neurones artificiels »,mémoire de magister,UMMTO,2011 .
- [9]: Rai, ND Kaushik A Mishra AK, « Solar Photovoltaics. s.l. : Springer » , 2018.
- [10] : J. Moein, U. Sener, « Analysis of Effects of Sun`s Position in the Sky on Solar Radiation and Solar Panel Output Power. s.l. : Electrical and Electronic Engineering Department », Eastern Mediterranean University.
- [11] : D. Ali, « Évaluation Des Pertes Dues À L'orientation Et À L'inclinaison Des Capteurs Solaires Photovoltaïques», Mémoire de Master, Université Mohamed Boudiaf M'sila, 2017.
- [12] : M. Zergat, « Effet De La Forme De Toiture Sur Le Confort Thermique », Mémoire de Master, Université Kasdi Merbah Ouergla, 2014.

- [13] : K. Danel, L. Gautret, « Génération du disque solaire des communes de l'Ouest », ARER, 2008.
- [14] : F. Merad, « Conception D'un Programme De Calcul Du Rayonnement Solaire, Cas Particulier De La Région De Mostaganem », Mémoire de Magister, Université Abdelhamid Ibn Badis Mostaganem, 2013.
- [15] : Y. Medjelled, « Effet de la Résistance Série sur les Performances d'une Cellule Photovoltaïque à Multi jonction sous concentration solaire. Approximation de forte injection » Mémoire de Magister, 2012.
- [16] : N. OleKsiy , « simulation, fabrication et analyse de cellule photovoltaïque à contacte arrières interdigités » Thèse de doctorat, L'institut national des sciences appliquées de Lyon 2005.
- [17] : S. Motahhir, A. El Ghzizal, A. Derouich « Modélisation et commande d'un panneau photovoltaïque dans l'environnement PSIM » Doctoral thesis, Submitted on 19 Apr 2018
- [18] : E. Parbaile, « Contribution à l'optimisation des techniques de dépôts sous vide de cellules solaires organiques », Thèse doctorat , Université de Limoges, 2009.
- [19] : F. Slama, « Modélisation d'un système multi générateurs photovoltaïques interconnectés au réseau électrique »,Magister électrotechnique ,Université F.Abbas ,setif
- [20] : M. Bacha Aissa, « Conception et réalisation d'une plateforme station météo connectée», Mémoire de Master, Université de Boumerdes, 2017.
- [21] : K. YEMMELI, « étude et dimensionnement d'une alimentation solaire pour sites de télécommunications. s.l », Mémoire de Master.
- [22] : A. Meddahi, A. REZIG.G, « Etude et conception d'un micro capteur de température et simulation sous COMSOL 4.3», Mémoire fin d'étude, Université Blida.
- [23]:M. Chaib, A. Daoulhadj , « Etude et réalisation d'une station météorologique »,Univ ADRAR,2020/2021
- [24] :A.Bara,« Etude et realisation d'une architecture de communication et de tests pour réseaux multi-capteurs MEMS dans les applications avioniques» , université de Qubec, Ecole de technologie supérieure.
- [25] : M. SOUILAH, « Etude et modélisation de capteurs piézoélectriques, piézorésistifs et capacitifs»,Thèse Doctorat, Université des Frères Mentouri Constantine.

- [26] :A. Bouaoud, I. Zermane, « Etude et réalisation d'un anémomètre sans capteur spécifique. »,master 2,univ Saad Dahleb Blida 1, 2019.
- [27] : M. Akermi, « Modélisation, Simulation Et Analyse Du Comportement D'un Capteur Solaire Plan À Eau Pour Différents Sites En Algerie» , Thèse de Doctorat, Université Abou Bekr Belkaid Tlemcen, 2019.
- [28] : H. HAMMOUCHE, «Conception et réalisation d'un capteur d'humidité à base des polymères hygroscopiques », THESE DE DOCTORAT, Université Mouloud Mammeri de Tizi-Ouzou.
- [29] : A. Angstrom, « Solar and terrestrial radiation », Quart J Roy Meteor.Soc, 1924, pp.121-126.
- [30] : JA. Prescott, « Evaporation from a water surface in relation to solar radiation », Trans Roy Soc Austr, Vol. 64, 1940, pp.114–118.
- [31] : H. Bulut, O. Bu`yu` kalaca, «Simple model for the generation of daily global solar-radiation data in Turkey», Applied Energy 84 (2007) 477–491.
- [32] : MR. Rietveld, « A new method for estimating the regression coefficients in the formula relating solar radiation to sunshine », Agric Meteorol, Vol. 19, 1978, pp.243.
- [33] : M. Chegaar, A. Cibani, «Global solar radiation estimation in Algeria», Energy Conversion and Management ,2001, pp. 967-973.
- [34] : K. Skeiker «Correlation of global solar radiation with common geographical meteorological parameters for Damascus province, Syria», Energy Conversion and Management 47 (2006) pp. 331–345.
- [35] : Page J.K. 1961. The estimation of monthly mean values of daily total short wave radiation on-vertical and inclined surfaces from sunshine records for latitudes 40°N–40°S», Proceedings of the United Nations Conference on New Sources of Energy 98(4): 378–390.
- [36] : R. Meenal , PG. Boazina , and AI. Selvakumar , 2016. Temperature based radiation models for the estimation of global solar radiation at horizontal surface in India», Indian Journal of Science and Technology 9(46).
- [37] : CK Pandey , A.K., Katiyar. 2010. Temperature base correlation for the estimation of global solar radiation on horizontal surface». *International Journal of Energy and Environment* 1: 737-44.



- [38] : KL. Bristow , G.S. Campbell. 1984. On the relationship between incoming solar radiation and daily maximum and minimum temperature ». *Agricultural and Forest Meteorology* 31: 159-166.
- [39] : A.H. Maghrabi, “Parameterization of a simple model to estimate monthly global solar radiation based on meteorological variables, and evaluation of existing solar radiation models for Tabouk, Saudi Arabia », *Energy Conversion and Management*, Vol. 50, 2009, pp. 2754–2760.
- [40] : A.A. Trabea, M.A. Mosalam Shaltout «Correlation of global solar radiation with meteorological parameters over Egypt », Suez Canal University, Egypt.
- [41] : F. Besharat, A. A. Dehghan , A. R. Faghieh «Empirical models for estimating global solar radiation: A review and case study», Yazd University, Iran.
- [42] : N. S. Chukwujindu «A comprehensive review of empirical models for estimating global solar radiation in Africa», University of Calabar, Nigeria.
- [43] : V. H. Quej , J. Almorox , M. Ibrakhimov, L. Saito, «Empirical models for estimating daily global solar radiation in Yucatán Peninsula, Mexico», University of Nevada Reno, USA.
- [44] : Y. El Houssaoui, Z. Hamadha, « Climatologie De La Duree D'insolation Dans La Region Sud » ,Mémoire de Master, Université Ahmed Draia Adrar, 2018.
- [45] : Site de la NASA: <http://eosweb.larc.nasa.gov/sse/>.
- [47] : A.A. El-Sebaia & A.A. Trabea, « Estimation of horizontal diffuse solar radiation in Egypt », *Energy Conversion and Management*, Vol. 44, 2003, pp. 2471–2482.

### **Abstract**

The growing demand of energy in our life pushes humanity into using renewable energy including solar energy.

Quantifying the solar radiation is the data set describing the evolution of the solar radiation at a given place and during a given period. Its study is the starting point of any investigation in the field of solar energy.

And our objectif in this work is to develop relationships between available meteorological data and solar irradiation , and to develop models to predict solar irradiation for the Bejaia site . Data of the different parameters was obtained from NASA , Afterwards, a multiple linear and nonlinear regression was applied to one part of these four meteorological data sets in different combinations yielding several relationships and models that were verified and validated using the second part of the data .

The various global solar irradiation prediction models obtained can be used in the design and performance estimation of solar applications in Bejaia as well as in the optimization and optimal sizing of solar systems.

### **Résumé**

La demande croissante d'énergie dans notre vie pousse l'humanité à utiliser les énergies renouvelables, y compris l'énergie solaire.

La quantification du rayonnement solaire est l'ensemble de données décrivant l'évolution du rayonnement solaire à un endroit donné et pendant une période donnée. Son étude est le point de départ de toute investigation dans le domaine de l'énergie solaire.

L'objectif de ce travail est de développer des relations entre les données météorologiques disponibles et l'irradiation solaire, et de développer des modèles pour prédire l'irradiation solaire pour le site de Bejaia. Les données des différents paramètres ont été obtenus de la NASA, Par la suite, un multiple linéaire et la régression non linéaire a été appliquée à une partie de ces quatre ensembles de données météorologiques dans différentes combinaisons produisant plusieurs relations et modèles qui ont été vérifiés et validés à l'aide de la deuxième partie des données.

les différents modèles globaux de prédiction de l'irradiation solaire obtenus peuvent être utilisés dans la conception et l'estimation des performances des applications solaires à Béjaïa ainsi que dans l'optimisation et le dimensionnement optimal des systèmes solaires .